

A SURVEY OF CUSTOMER RETENTION IN THE NEW ZEALAND BANKING INDUSTRY

Christopher Gan^{*}, David Cohen^{**}, Mike Clemes^{***}, Esther Chong^{****}

Abstract

Previous banking studies on customer retention focused narrowly on customer loyalty and customer satisfaction without attempting to link them in a model to further explore or explain customer retention. If retention criteria are not well managed, customers may still leave their banks, regardless of how hard bankers try to retain them. This study empirically examines the potential constructs in customer retention by investigating the chain of effects of retention from customer satisfaction, customer value, corporate image, switching barriers to competitive advantage. In general, all of the hypotheses tested were supported except for higher levels of customer satisfaction do not necessary lead to customer loyalty. Customers can be highly satisfied but still leave their current banks. It is assumed that when the customer is completely satisfied, then loyalty towards the bank is strengthened.

Key words: customer satisfaction, customer loyalty, customer retention.

JEL classification: G20, M30.

1. Introduction

The competitiveness in the banking industry has increased significantly in recent years due to deregulation and globalization. Since the products and services offered by banks can often be easily duplicated, banks are not only competing with each other but also with other non-banks financial institutions (Hull, 2002). When banks provide nearly identical services, they can only distinguish themselves on the basis of price and quality.

Banks in New Zealand are mainly foreign-owned and they are not very diversified. As a result, the New Zealand banking industry has reached saturation and has become commoditized since banks offer nearly identical products. Such evidence suggests that banks in New Zealand have reached the maturity phase of the product lifecycle. This carries the danger of creating a downward spiral of perpetual discounting – fighting for customer share (Mendzela, 1999). Thus, it is essential for bank management to try their best to retain as many customers in order to remain viable.

From a cost perspective, retaining an existing bank customer costs less than creating a new one. The cost of creating a new customer has been estimated to be five times more than that of retaining an existing customer (Reichheld, 1996). Banks seek to achieve a zero defection rate of profitable customers, to minimize the customer churn; the acquisition and subsequent loss of customers (Farquhar, 2004). In addition, longer-term customers buy more and, if satisfied, may generate positive word-of-mouth promotion for the banks (Reichheld & Kenny, 1990). Furthermore, long-term customers also take less of the bank's time and are less sensitive to price (Healy, 1999). As a consequence, retaining customers becomes a priority and there are compelling arguments for bank managers to more carefully consider the factors that might increase customer retention rates.

Previous researches have also shown that longevity does not automatically lead to profitability (Colgate, Stewart, & Kinsella, 1996). A bank cannot claim to have loyal clients, unless customers express their future commitment to use the bank's services and their willingness to consider the bank's new financial strategies and services. In addition, loyal clients will also show their

* Lincoln University, New Zealand.

** Lincoln University, New Zealand.

*** Lincoln University, New Zealand.

**** Standard and Chartered Bank, Malaysia.

resistance to competitors' enticements and be willing to give their current bank both solicited and unsolicited referrals.

Previous banking studies on customer retention focused narrowly on customer loyalty and customer satisfaction without attempting to link them in a model to further explore or explain customer retention. If retention criteria are not well managed, customers may still leave their banks, regardless of how hard bankers try to retain them. This study empirically examines the potential constructs in customer retention by investigating the chain of effects of retention from customer satisfaction, customer value, corporate image, switching barriers to competitive advantage. The links between these constructs are tested to determine if the results are consistent with previous claims about the factors that impact retention. These factors include: 1) the links between customer satisfaction, customer value and bank image, 2) the links between competitive advantage, customer satisfaction, customer value, bank image and the switching barriers with regard to consumers' behavioural intentions and customer loyalty, and 3) the links between consumers' behavioural intentions and customer loyalty with regard to customer retention.

The remainder of this paper is organized as follows. Section 2 presents a review of the customer retention literature and presents testable hypotheses. Section 3 outlines the research methodology. The results and discussions are then presented in Section 4. Section 5 concludes the paper.

2. Literature Review

Previous studies have identified the benefits that customer retention delivers to an organisation (see Colgate et al., 1996; Reichheld and Sasser, 1990). For example, the longer a customer stays with an organisation the more utility the customer generates. This utility is an outcome of a number of factors relating to the time the customer spends with the organisation, including the higher initial costs of introducing and attracting a new customer; an increase in the value of purchases; an increase in the number of purchases; the customer's better understanding of the organisation and positive word-of-mouth promotion.

Apart from the benefits that longevity of customers creates, researchers also suggest that the costs of customer retention activities are less than the costs of acquiring new customers. For example, Rust and Zahorik (1993) argue that the financial implications of attracting new customers may be five times as costly as keeping existing customers. However, maintaining high levels of satisfaction does not ensure all customers remain loyal. Banks lose some satisfied customers who have moved, retired, or no longer need certain services.

Beckett et al. (2000) draw tentative conclusions as to why consumers appear to remain loyal to the same financial provider, even though, in many instances, they hold less favourable views toward their service providers. For example, consumers appear to perceive little differentiation between financial providers. They may be motivated by convenience or inertia. Finally, many consumers associate high switching costs in terms of the potential sacrifice and effort involved with changing banks.

Stum and Thiry (1991) argue that retained customers do demonstrate immunity to competitive pull. This is supported by Strandvik and Liljander (1994) in an exploratory study of customer relationship strength in retail banking in Finland. They found that if the bank-customer relationships were strong and that customers did not pay attention to competitors' advertising or make comparison to other banks. These findings are similar to Christopher et al.'s (1991) study that suggested prospective customers become actual customers and move along the "ladder of customer loyalty" to become clients, then supporters and, finally, advocates.

Customer satisfaction has for many years been a key determinant in explaining why customers leave or stay with an organisation. Every organisation needs to know how to retain their customers, even if they appear to be satisfied. Reichheld (1996b) suggests that some unsatisfied customers may choose not to defect, because they do not expect to receive better service elsewhere and

that some satisfied customers may look for other providers if they believe they can get better services elsewhere. Customer satisfaction is viewed an important indicator of customer retention but customer satisfaction is not always an assurance of customer retention. Retaining customers is also dependent on a number of other factors such as choices, conveniences, prices, and incomes (see Richards, 1996; Jones and Sasser, 1995).

Customer retention is thought to improve profitability, principally by reducing costs incurred in acquiring new customers; the prime objective being “zero defections of profitable customers” (Reichheld, 1996b). There is, however, a distinction between customers who are retained and those who are loyal. The inertia prevalent within the industry of financial services implies that customers may be retained may not necessarily be loyal. True loyal customers are usually portrayed as being less price-sensitive and more inclined to increase the number and/or frequency of purchases. They may become advocates of the organisation concerned and either directly or indirectly influence the decision making of their peers or family.

The links between customer loyalty and organisational profitability have been also demonstrated, suggesting that an organisation with loyal customers enjoys considerable competitive advantage (Reichheld, 1996b). Loyal customers have a positive effect on customer retention but customer loyalty is not customer retention. Loyalty is only a valid concept in situations where customers have options to choose from. The main issue is that retention should not be taken as a substitute for loyalty and this suggests that banks need to understand why their consumers choose to stay and should not assume that it is a positive conscious choice (Colgate et al., 1996).

Similarly, repurchase alone is not an indicator of loyalty. In financial services, continued customer support, which might even include extending the range of purchases, can often be an indication of inertia. Behavioural patterns form only one component of loyalty and if the consumer does not demonstrate a favourable attitude towards a brand or company, there is an increased chance of switching. Customers may be lured away by attractive offers made by competitors when they experience dissatisfying incidents (Jones and Farquhar, 2003).

Clearly, there are compelling arguments for bank management to carefully consider the range of factors that increase customer retention rates. To date, there is a wealth of research advocating the importance of customer retention in the banking industry (see Fisher, 2001; Marple and Zimmerman, 1999). However, there has been little empirical research undertaken to investigate the constructs that lead to customer retention in the banking industry. Previous empirical work has focused on identifying some of the constructs that are thought to be precursors to customer retention and other studies have focused on developing a measure of customer satisfaction, customer value and customer loyalty without, examining other potential constructs (such as competitive advantage, customer satisfaction, switching barriers, corporate image and behavioural intentions) and their link to customer retention.

2.1. Customer Retention

Most of the research in customer retention and customer exit investigates the processes separately without linking the two processes together (Colgate and Norris, 2001). Based on the previous literature, this study developed a customer retention model linking several major constructs that are proposed to impact a customer’s decision to stay with, or leave, his or her current bank (see Figure 1). The literature suggests that there is a positive relationship between consumers’ behavioural intentions and customer loyalty and customer retention in banks. Furthermore, there is a positive relationship between customer satisfaction and customer value and consumers’ behavioural intentions and customer retention. Similarly, there is a positive relationship between competitive advantage, customer satisfaction, customer value, corporate image, switching barriers, customer loyalty, and customer retention.

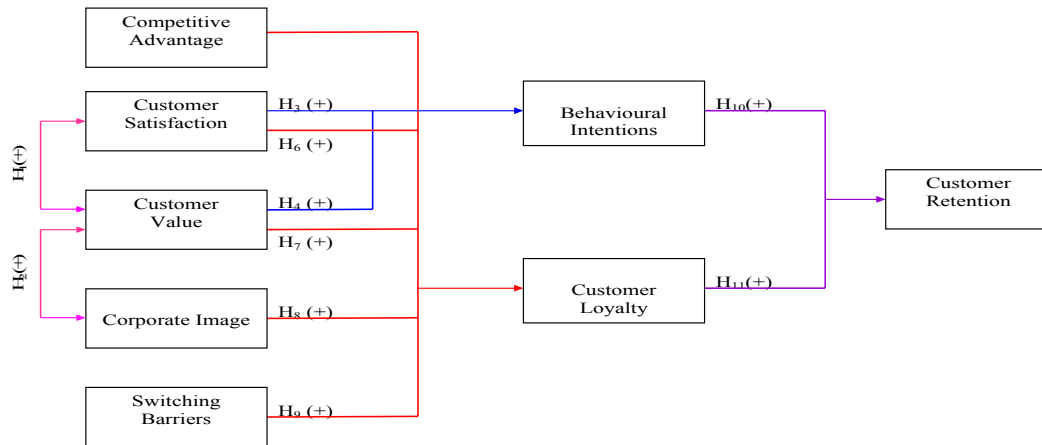

Fig. 1. Research Model of the Relationships between Constructs Impacting Customer Retention

2.1.1. Relationship between Customer Satisfaction and Customer Value

Many banks choose not to engage in price wars however service can be an effective competitive tool. Varki and Colgate (2001) argued that nothing can replace quality service. Quality service, as perceived by the customer, has an effect on the perceived value of the service rendered. The relationships between the service events, the customer's prior and post perceptions, and perceived and actual quality of delivered service all jointly determine the success or failure of generating value (Grot and Dye, 1999). Woodruff (1997) argues that the concept of customer value suggests a strong link to customer satisfaction. Both concepts describe evaluative judgments about products, and both place special importance on the use situation.

Spreng et al. (1996) suggested that customers create a set of objectives, learned from past and present experiences, about what value they desire in the process of making an evaluation. The customer value hierarchy suggests that desired value is composed of a preference for specific and measurable dimensions; the attributes, attribute performances, and consequences linked to goals for use situations. Desired value, in turn, guides customers when they form perceptions of how well or poorly a product has performed in the use situation. That is, they evaluate use experiences on the same attributes, attribute performance, and consequences constructed in their desired value hierarchies. Further, Siles et al. (1994) reported that customers have always been reluctant to switch banks, but impersonal, unfriendly service will still drive them away.

Five dimensions of service quality are employed in this study. These include convenience, reliability, features and facilities, staff who deliver the service, and tangibles. The support element is concerned with all aspects of how service quality can be provided to add value (Devlin, 2001). Hence, customers' satisfaction is affected by their perceived value and vice versa. For example, Varki and Colgate's (2001) demonstrated that customer value impacts customer satisfaction and there is an inter-linkage between perceived service value and customer satisfaction evaluation. The following hypothesis is proposed:

H₁: There is a positive relationship between the level of perceived service value and the level of customer satisfaction.

2.1.2. Relationship between Corporate Image and Customer Value

Image is viewed as a cumulative construct that is updated each time the customer experiences the service. As for the influence of perceived service value on corporate image, Barich and Kotler (1991) propose that a company will have a strong image if customers believe that they are getting high value when they make a purchase. Accordingly, a number of factors such as quality products, quality services and reasonable prices are deemed to influence value judgement.

Gronroos (1984) argues that corporate image is built mainly by technical quality, i.e. what the customer receives from the service experience, the functional quality, and the manner in which the service is delivered. Bitner (1990) proposes that cues from the physical environment are instrumental in communicating the firm's purpose and image. Baker (1993) contends that a positive ambiance has considerable influence on employee motivation and the quality of the service encounter.

Interestingly, physical environment and contact personnel are integral parts of service quality identified by Parasuraman et al. (1988). The assumption is that customers who perceive service quality over repeated service encounters have an overall favourable image of the firm. Similarly, since customer satisfaction is described as a judgement made on the basis of a specific service encounter (Cronin and Taylor, 1992), satisfaction levels derived from each service encounter are viewed as having an effect on image assessments.

The overall image of the service firm is influenced by perceived service quality, customer satisfaction, and by perceived service value. These links have also been tested by Ngu and LeBlanc (1998). The authors argue that corporate image remains in the minds of consumers in the form of attitude and behavioural intentions. Corporate image can then provide added value to consumers (Devlin, 2001). Further, corporate image is also seen as a competitive advantage, which has the ability to create and maintain superior "customer value". Bankers therefore must create a brand environment in which the personnel, the physical layout, the use of technology and the banking products collaborate to serve and support a customer experience of value (Bachman, 2001).

Having outlined the existing literature relevant to these constructs, it is reasonable to argue that creation of corporate image and perceived service value are mutually moderating. Indeed, understanding the role of corporate image in the customer retention decision both as an antecedent and consequence is a key issue that has received little attention in the banking industry arena. The following hypothesis is proposed:

H₂: There is a positive relationship between the level of corporate image creation and the level of customer assessments of perceived value.

2.1.3. Relationship between Customer Satisfaction and Consumers' Behavioural Intentions

Parasuraman et al. (1994) propose a transaction-specific conceptual model that views a customer's overall satisfaction with a transaction to be a function of service quality, product quality, and price. The role of price, as an attribute of performance, has been examined in several satisfaction studies. By managing the comparative price perceptions of their customers, managers could simultaneously influence overall customer satisfaction and behavioural intentions, because of comparative price perception's direct effect on these constructs.

Customer satisfaction presumably has a positive effect on consumers' behavioural intentions. La-Barbera and Mazursky (1983), building on Oliver's (1980) cognitive model, provide empirical evidence that satisfaction mediates the difference between previous intentions and revised intentions, to produce a relationship which is stronger than simply the direct effect of previous period intentions on present periods. This evidence would lead to the expectation that satisfaction will lead to higher repurchase intentions. Indeed, Anderson and Sullivan (1993) found that intentions were positively influenced by the level of satisfaction. Those firms with higher satisfaction levels tended to have lower retention elasticity. This conclusion is based on strong evidence in the literature of a relationship between satisfaction levels and behavioural intentions. The following hypothesis is proposed:

H₃: Higher levels of customer satisfaction lead to favourable customer's behavioural intentions.

2.1.4. *Relationship between Customer Value and Consumers' Behavioural Intentions*

Although price is traditionally viewed as relatively unimportant in financial services, the potential to use a low price to add value has been acknowledged. Devlin (2001) proposed that adding value may be used to achieve competitive advantage which, in turn, could increase consumers' positive behavioural intentions. Higher levels of customer value will lead to higher levels of customer satisfaction. Given the positive relationship between customer satisfaction and customer value, it is hypothesized that customer value will also influence consumers' behavioural intentions. The following hypothesis is proposed:

H₄: Higher levels of customer value lead to favourable customer's behavioural intentions.

2.1.5. *Relationship between Competitive Advantage and Customer Loyalty*

In today's competitive environment, banks need to keep up with current and potential customers if they are to survive, grow and continue to prosper (Mohebi and Hechter, 1993). This finding is supported by Holliday (1996) where the banking industry is vulnerable to a changing environment for example loyal customers can be stolen away through an aggressive marketing campaign. Thus, product and service differentiation and marketing campaigns are important factors to sustain competitive advantage in the industry. This is supported by Mylonakis et al.'s (1998) findings that showed that banks today are focusing most of their competitive efforts on physical presence (such as branch network development in very attractive locations) and promotion, as well as offering supplementary services to differentiate themselves from others (Mylonakis et al., 1998).

The homogeneity of services offered and competition within the banking industry have put added pressure on banks to achieve competitive differentiation, which has led to an emphasis on service quality. Banks use service quality as a means of gaining competitive advantage. This practice is perceived to be a prerequisite for achieving high quality customer service, which is seen as the only mechanism for achieving differentiation and retaining customers in a highly competitive and homogenous industry (Ioanna, 2002).

Chang et al. (1997) further identified a need for bank managers to look into the quality aspects of their products and to establish quality control systems for providing services that are consistent and at levels exceeding customers' expectations. The authors conclude that a bank should extend its product quality beyond the core service and expected service with additional and potential service features to be remembered and distinguished by customers. The following hypothesis is proposed:

H₅: Perceived competitive advantage has a positive effect on customer loyalty.

2.1.6. *Relationship between Customer Satisfaction and Customer Loyalty*

Chong et al. (1997) found that both customer satisfaction and customer perceptions of service quality were important predictors of attitudinal loyalty, but that satisfaction had the strongest relationship with the loyalty construct. Thus, satisfaction is only of value to firms if it elicits some kind of positive financial outcome. Furthermore, Colgate and Danaher (2000) examined the effects that implementation of a relationship strategy can have on overall customer satisfaction and loyalty. Indeed, it was found that service organisation employees form particularly close relationships with customers because employees and customers often work together in the creation of many services, where services are produced by employees and consumed by customers simultaneously (Lovelock, 1981; Berry, 1980). In addition, because of the intangibility of services, customers often rely on employees' behaviour in forming opinions about the service offering (Gronroos, 1984; Shostack, 1977). Because of these functions, employees actually become part of the service in the customer's eyes (Lovelock, 1981).

Similarly, Anderson and Sullivan (1993) found that repurchase intentions were positively influenced by satisfaction across product categories, and that customers were more likely to be retained as satisfaction increased. The positive effect of customer satisfaction on brand loyalty is also noted by LaBarbera and Mazursky (1983) and Kasper (1988). Oliver (1999) found that when satisfaction with services went above a critical point, customer loyalty also increased. To achieve customer loyalty, the author maintains that all service encounters offer an opportunity to provide superior service and to distinguish the firm from its competitors. Consequently, customer satisfaction is considered to be an antecedent to service loyalty. The following hypothesis is proposed:

H₆: Higher levels of customer satisfaction lead to higher levels of customer loyalty.

2.1.7. Relationship between Customer Value and Customer Loyalty

The major approach to predict customer loyalty draws from the evaluative judgement of variables, especially the satisfaction-loyalty model (Loveman, 1998). This standard approach posits that increased loyalty results from higher levels of customer satisfaction. While some authors claim that customer satisfaction is not enough to drive customer loyalty, other scholars argue that the solution is to add value to the transaction (Stum and Thiry, 1991). Customer loyalty is earned by consistently delivering superior value (Reichheld, 1993). Few studies have been conducted that link value for money with service outcomes. However, in a retail service, Sweeney et al. (1997) found that value for money had a significant and positive effect on the customer's willingness to buy an electrical appliance.

Butcher et al. (2001) support the efficacy of customer satisfaction as the major predictor of service loyalty. More importantly, their study shows that satisfaction with a single service encounter is critical to loyalty formation. However, friendship between customers and particular service employees also has a major influence on the development of loyalty. It also appears that value for relationship and service quality are the major variables in forming customer loyalty. The following hypothesis is proposed:

H₇: Higher levels of customer value lead to higher levels of customer loyalty.

2.1.8. Relationship between Corporate Image and Customer Loyalty

Many financial institutions agree that building brand awareness and positive perception of brands are cumulative and sometimes painstaking processes. Every brand should be looked at as a promise of certain provider attributes and values such as promise of quality, level of service and performance to be expected (Alvarez, 2001). Furthermore, branding is a customer-focused activity. Brands exist to help consumers make choices among several products or services. A well-managed brand with a strong image can increase customers and build a more loyal franchise (Bergstrom and Bresnahan, 1996). The following hypothesis is proposed:

H₈: Higher levels of corporate image lead to higher levels of customer loyalty.

2.1.9. Relationship between Switching Barriers and Customer Loyalty

Marple and Zimmerman (1999) have suggested that the cross-selling of banking services is more important today than before. Many bankers pointed out that their retention rates have increased in parallel with the rate at which customers begin using more products (Daniell, 2000). Noe (1996) further discovered that customers who have several accounts with a bank are much more likely to remain loyal. Colgate and Norris (2001) found that barriers to exit include the amount of time and inconvenience it would take to switch banks, having to get new cheque books, to transfer funds, and having to learn a new cash management system. The amount of paperwork involved, issues with existing loans and guarantees, and a good history and rapport with their current bank also seemed to be factors inhibiting complaints.

Butcher et al.'s (2001) study highlights that loyalty construction precludes changing service providers. This has been expressed as the bonding to another when it seems contrary to self-interest (Gilmore and Czepiel, 1987) or demonstrates a resistance to the pull of the competition (Stum and Thiry, 1991). This theme is also supported by Oliver (1997), who expressed loyalty as a commitment to repurchase against the odds and costs. Fisher (2001) further identified that some people see little advantage to be gained in switching bank accounts. They therefore prefer to stay with their current banks, although they might not be satisfied with the offerings. The following hypothesis is proposed:

H₉: Higher levels of switching barriers lead to higher levels of customer loyalty.

2.1.10. Relationship between Consumers' Behavioural Intentions and Customer Retention

Changing customer preferences and spending patterns will influence consumers' behaviour. For example, Beckett et al. (2000) found that consumers transferred their accounts to alternative providers because of lifestyle changes, such as marriage, or moving house. Abratt and Russell (1999) have shown that price is the most important criterion in the selection of a private bank. This is followed by trust, service quality and the bank being available at a time of crisis. The authors also show that customers are more likely to be retained by the bank when they have a personal banker or financial consultant. In contrast, Rigall (1980) confirmed that the convenience factor is the most important for bank customers, followed by friends' suggestions and low service charges. Lewis (1991) found that convenience and recommendations by friends and family were the most decisive bank selection criteria.

Many factors influence the choice of a bank. Previous studies have concluded that the most important factors are convenience, bank reputation or image, quality of services, range of products offered, interest rates and fees (prices), as well as responsiveness to consumers' needs (Mylonakis et al., 1998). Therefore, the factors that might influence consumers' behavioural intentions in this study include locations, bank's image, service quality, a variety of products, price and bank's ability to meet consumers' changing needs. The following hypothesis is proposed:

H₁₀: Favourable consumers' behavioural intentions will have a positive effect on customer retention.

2.1.11. Relationship between Customer Loyalty and Customer Retention

Loyal clients are believed to be less price-sensitive (Clark et al., 1995) but this conflicts with Abratt and Russell (1999) findings where the authors found that reasonable prices are rated as an important requirement for consumers to stay loyal. This is also supported by Fisher (2001), who identified that a key factor in loyalty to any brand is price. As consumers are given more choices, they appear to be more willing to try new brands, especially if they do not feel 'rewarded' for remaining loyal, and they perceive many brands to be equal in terms of quality and value received (Schriver, 1997).

To address the problem of customer defection, loyalty programmes have been implemented to encourage multiple product sales (Healy, 1999). These include discounted rates for credit products, improved rates for deposit products, discounts for rental vehicles, frequent flyer programmes, retirement plans, insurance, and others. Ennew and Binks (1996) found that loyal clients enjoy a better relationship with the bank. By building relationships with clients, banks get to know the needs of their clients better and meet (or exceed) their expectations. Personal friendship between a customer and an individual service employee has also been modeled to influence customer loyalty (Bove and Johnson, 2000). Price and Arnould (1999) found that customer loyalty may be cultivated or strengthened, as customers find entertainment value or highly satisfying personal relationships in their interaction with the service provider.

Apart from personal relationships, a service recovery effort is also necessary, where a service provider is notified that a problem has occurred (Trubik and Smith, 2000). A service recovery process encompasses all the actions taken to get a disappointed customer back to a state of satisfaction. The plethora of literature on service recovery, both managerial and academic suggests that service recovery is the most important factor in driving a customer to exit or stay after a service failure. As a result, switching behaviour can increase, as do complaints, cynicism toward the concept of loyalty, and litigious activities (Schriver, 1997).

H₁₁: Favourable customer loyalty will have a positive effect on customer retention.

3. Methodology and Data

Data for this analysis was obtained through a mail survey sent to 1,920 respondents in Christchurch. Respondents were asked to identify their preferences, loyalty and other factors they thought would influence their bank evaluation. The mail survey was designed and implemented according to the Dillman Total Design Method (1978), which has proven to result in improved response rates and data quality. The questions were phrased in the form of statements scored on a 5-point Likert-type scale, where 1 = "strongly disagree", 3 = "neither disagree nor agree", and 5 = "strongly agree".

The names and addresses for the mail survey were systematically drawn from the 2004 Christchurch Telephone Book. The sampling procedures were based on Malhotra (1999) and Proctor (1997) recommendations. From the 140,462 listings in the 2004 Christchurch Telephone Book, every 73rd (140,462/1,920) potential participants were selected accordingly. A total of 514 useable surveys were returned from the 1,920 mailed out surveys resulting in a useable response rate of 28%.

The purpose of this study is to determine the nature and extent of relationships between the constructs identified as factors influencing customer retention. Multiple regressions are used to test the hypothesized relationships among the identified constructs.

4. Results and Discussions

4.1. Descriptive Statistics

A profile of sampled respondents is presented in Table 1. From the total of 514 useable questionnaires, the sample respondents are comprised of 51.8% males and 48.2% females, and 50.1% of the respondents have a diploma. The majority of the survey respondents were between 31 to 40 years (24.23%) and 41 to 50 years (24.23%) a bi-modal distribution. Panel D illustrates the personal income of respondents ranged from 'less than \$10,000' to 'more than \$120,000' earnings p.a. before tax. This suggests that income of respondents is not normally distributed. The mode of the sample earnings is between \$30,000-\$39,999 p.a.

According to Table 2, 78.9% of respondents have been banking with their banks for more than five years. Westpac has the highest 5-year retention rate of 33.3%, followed by ANZ/National Bank at 26.2%. However, this does indicate that Westpac is the most efficient in retaining its customers. When surveyed on likelihood of staying with their service provider (see Table 3), it was found that Westpac has the lowest mean score of 3.59, suggesting that Westpac's customers might be somewhat more willing to switch to other service providers.

On the other hand, banks with lower retention rate such as ASB Bank (5.9%), Kiwibank (0%) and banks under 'other' categories (2.2%) have higher mean scores of 4.09, 4.22 and 4.38, respectively (see Table 3). This suggests that the respondents who bank with ASB, Kiwibank and 'other' banks are more likely to stay with their bank and to continue purchasing the services and products from these providers.

Table 4 provides a summary of a mean response for each of the constructs. The mean responses are calculated based on the average response of each questions attributed to a particular construct in the questionnaire. For example, customer satisfaction was measured using a nine-item index. The respondents had a mean score of perceived satisfaction of 4.02. The accuracy of banking records and of transactions yielded the highest satisfaction scores by the respondents. The lowest mean score for the satisfaction construct was pricing.

Table 1

Demographics of Respondents

Demographic	Frequency	Valid Percent	Cumulative Percent
Panel A: Age Group			
18-30 years old	43	8.4	8.4
31-40 years old	92	17.9	26.3
41-50 years old	124	24.2	50.5
51-60 years old	124	24.2	74.7
61-70 years old	66	12.9	87.5
71 years old and above	64	12.5	100
Total	513	100	
Panel B: Gender			
Male	265	51.8	51.8
Female	249	48.2	100
Total	512	100	
Panel C: Education Level			
Postgraduate Degrees	60	12.5	12.5
Bachelor Degree	100	20.9	33.4
Diploma	80	16.7	50.1
Trade Qualification	72	15.0	65.1
High School Qualification	167	34.9	100
Total	511	100	
Panel D: Income Level			
Less than \$10,000	49	9.8	9.8
\$10,000-\$19,999	79	15.9	25.7
\$20,000-\$29,999	61	12.2	38.0
\$30,000-\$39,999	81	16.3	54.2
\$40,000-\$49,999	76	15.3	69.5
\$50,000-\$59,999	40	8.0	77.5
\$60,000-\$69,999	27	5.4	82.9
\$70,000-\$79,999	27	5.4	88.4
\$80,000-\$89,999	7	1.4	89.8
\$90,000-\$99,999	7	1.4	91.2
\$100,000-\$120,000	21	4.2	95.4
\$120,000 +	23	4.6	100
Total	498	100	

Table 2

Bank of Respondents

Length of stay	RESPONDENT'S BANK													
	ASB		ANZ/National		BNZ		Kiwibank		Westpac		Other		Total	
< 1 year	4	.8%	5	1%	5	.2%	2	.4%	2	.4%	1	.2%	15	3%
1-2 years	1	.2%	5	1%	3	.6%	7	1.4%	3	.6%	2	.4%	21	4.1%
2-3 years	3	.6%	12	2.4%	6	1.2%	4	.8%	4	.8%	2	.4%	31	6.1%
3-4 years	5	1%	5	1%	4	.8%	0	0%	1	.2%	1	.2%	16	3.1%
4-5 years	8	1.6%	11	2.2%	3	.6%	0	0%	0	0%	2	.4%	24	4.7%
> 5 years	30	5.9%	133	26.2%	58	11.4%	0	0%	169	33.3%	11	2.2%	401	78.9%
Total	51	10%	171	33.7%	75	14.8%	13	2.6%	179	35.2%	19	3.7%	508	100%

Table 3

Mean Retention Rate by Banks

Bank	Number	Mean	Std. Deviation
ASB	51	4.09	.694
ANZ/National Bank	171	3.74	.731
BNZ	75	3.97	.698
Kiwibank	13	4.22	.759
Westpac	179	3.59	.684
Other	19	4.38	.813
Total	508	3.79	.738

Table 4

Respondents' Mean Responses to the Main Constructs

CONSTRUCTS	No.	Mean Responses	Std. Deviation	No. of Items	Alpha Value
Customer Satisfaction	514	4.02	.644	9	.851
Customer Value	514	3.54	.730	8	.838
Corporate Image	514	3.90	.691	7	.865
Competitive Advantage	514	3.43	.787	5	.850
Switching Barriers	514	3.79	.758	7	.819
Consumers' Behavioural Intentions	512	3.58	.779	6	.846
Customer Loyalty	513	3.35	.735	6	.766

4.2. Analysis of Hypothesized Relationships

4.2.1. Reciprocal Model (H1 and H2)

Table 5 presents the results of the influence of customer satisfaction (SATISFACTION) and corporate image (IMAGE) on customers' perceived value (VALUE). The results show customer sat-

isfaction and customers' perceived image of the bank had a significant effect on consumers' perceived value. The results are consistent with previous findings in the literature, which have suggested that customer's satisfaction level is closely connected to perceived value (Spreng et al., 1996; Woodruff, 1997). Barich and Kotler (1991) acknowledged that there is integration of consumers' perceived value and perceived image. This indicates customers will build a strong image of their bank if they perceive that they are receiving high value from what they purchase.

Table 5

Regression of Satisfaction and Image against Perceived Value

Dependent Variable is Perceived Value				
Variables	Coefficients (β)	t-Values	Sig	Outcome
Constant		-.767	.443	
Satisfaction (+)	.508	12.997	.000 H1	Supported
Image (+)	.323	8.276	.000 H2	Supported
Adjusted R ² = .587		F = 365.985; p = .000		DW Statistic = 1.894 ¹
MODEL: Value = β + β_1 SATISFACTION + β_2 IMAGE + ϵ				

4.2.2. Intentions Model (H3 and H4)

Table 6 shows the results of the influence of customer satisfaction (SATISFACTION) and customer value (VALUE) on customer's behavioral intention (INTENT). The results show a significant positive relationship between customer satisfaction and customer perceived value and consumer's behavioural intentions, supporting *H₃* & *H₄*. These findings imply that the respondents will produce revised intentions of continuity of patronage if they received valued products or services and they are satisfied with the bank's performance. The results are consistent with Anderson and Sullivan (1993) findings. Such findings are important because repurchase intentions will lead to a higher possibility of customer retention, which was proposed in *H₁₀* and supported by the analysis.

Table 6

Regression of Satisfaction and Value against Intentions

Dependent Variable is Intent				
Variables	Coefficients (β)	t-Values	Sig	Outcome
Constant		3.778	.000	
Satisfaction (+)	.252	5.210	.000 H3	Supported
Value (+)	.460	9.514	.000 H4	Supported
Adjusted R ² = .441		F = 202.775; p = .000		DW statistic = 2.143
MODEL: Intent = β + β_1 SATISFACTION + β_2 VALUE + ϵ				

¹ Durbin-Watson Statistic's successive residuals should be $1.7 < D < 2.3$, $n > 100$, with 95% confidence interval.

4.2.3. Loyalty Model (H5, H6, H7, H8 & H9)

Table 7 shows the results on the relationship between customer loyalty and competitive advantage, customer satisfaction, customer value, corporate image and switching barriers. The results show positive relationships between the predictor and the outcome. However, customer satisfaction does not make a significant contribution to customer loyalty when other variables are taken into consideration. Furthermore, the coefficient between customer satisfaction and customer loyalty was close to zero ($\beta = .006$) suggesting that customer satisfaction does not necessarily lead to customer loyalty in New Zealand's banking industry. Thus, H_6 is not supported. The results support Hotchkiss's (1995) findings where consumers can be highly satisfied but still leave their service providers. The results also show that competitive advantage, customer value and switching barriers had a significant impact on customer loyalty. Of the five dimensions evaluated, corporate image created by the service provider was the least important dimension.

These results are consistent with Butcher et al., (2001); Noe (1996) and Oliver's (1999) findings. As the financial services marketplace becomes increasingly competitive, with new banks pursuing profitable customers, customer loyalty will play a greater role in the success of established providers of financial services (Jones and Farquhar, 2003). It is generally assumed that when the customer is completely satisfied, then loyalty towards the bank is strengthened (Jones and Farquhar, 2003). However, the results in this study showed that customer satisfaction is a non-significant contribution to customer loyalty. This means that customer satisfaction is not a major factor influencing consumers' decisions to stay loyal to their banks.

Table 7

Regression of Satisfaction, Value, Image, Competitive Advantage and Switching Barriers against Loyalty

Dependent Variable is Loyal				
Variables	Coefficients (β)	t-Values	Sig	Outcome
Constant		1.140	.255	
Competitive (+)	.181	3.694	.000 H5	Supported
Satisfaction (+)	.006	.134	.894 H6	Not supported
Value (+)	.184	3.737	.000 H7	Supported
Image (+)	.093	1.967	.050 H8	Supported
Barrier (+)	.418	10.735	.000 H9	Supported
Adjusted R ² = .580		F = 142.370; p = .000		DW statistic = 2.026
MODEL: Loyal = β + β_1 SATISFACTION + β_2 VALUE + β_3 IMAGE + β_4 COMPETITIVE +				
	β_5 BARRIER + ϵ			

4.2.4. Retention Model (H10 & H11)

Table 8 shows the results of the influence of customers' behavioural intentions (INTENT) and customer loyalty (LOYAL) on customer retention. The results show both consumers' behavioural intentions and customer loyalty are significant predictors of customer retention. The results are consistent with prior expectations (Colgate and Norris, 2001; Healy, 1999), that both constructs would affect consumers' likelihood to stay with or leave their bank in the future. Specifically, favourable behavioural intention was found to be a strong indicator of retaining banking consumers. This in turn suggests that consumers are more willing to stay with their providers if the banks are

proactive and are able to meet their changing demands rather than only satisfying consumers' basic banking needs.

However, it should be emphasised that these two constructs (consumers' behavioural intentions and customer loyalty) can only explain 34% of the retention variance. Such a result is acceptable as demographic variables also contributed to the customer retention construct.

Table 8

Regression of Intentions and Loyalty against Retention

Dependent Variable is Retention				
Variables	Coefficients (β)	t-Values	Sig	Outcome
Constant		12.151	.000	
Intent (+)	.508	7.224	.000 H10	Supported
Loyal (+)	.323	5.722	.000 H11	Supported
Adjusted R ² = .336		F = 130.570; p = .000		DW Statistic = 2.043
MODEL: Retention = β + β_1 INTENT + β_2 LOYAL + ϵ				

5. Conclusions

In general, all of the hypotheses tested were supported except for higher levels of customer satisfaction do not necessary lead to customer loyalty. This finding supports Hotchkiss's (1995) study where the author found that consumers can be highly satisfied but still leave their service providers. However, some customers do perceive that alternative banks provide the same (or a similar) services as their present banks and they feel they would be no better off from switching to other banks. The findings in this study provide strong support for the applications of customer retention model in New Zealand banking industry. It is imperative for banking executives to improve performance on each construct that leads to customer retention to improve their competitiveness in the banking industry. Customer satisfaction does not necessarily lead to customers' loyalty. It is assumed that when the customer is completely satisfied, then loyalty towards the bank is strengthened. Furthermore, the results show the respondents in this study have a positive impression towards their banks' ability to meet their changing needs. This demonstrates that the respondents would likely stay with their banks as long as their banks are able to satisfy their changing needs proactively.

New Zealand banks are not very diversified and retaining customers is one of the most important strategies available to New Zealand banks to remain competitive. Bank management should place more emphasis on customer retention than attracting new customers since it is less expensive to retain current customers than to bring in new ones. In addition, consumers' banking behaviour has changed and contemporary consumers have higher propensities to switch banks every now and then.

References

1. Abratt, R., J. Russell. Relationship Marketing in Private Banking South Africa. // The International Journal of Bank Marketing, 1999, Vol. 17, No. 1, pp. 5-19.
2. Alvarez, E.J. (2001). Your Bank's Image: Keeping it Consistent // Bank Marketing, 2001, Vol. 33, No. 3, April, pp. 30-36.

3. Anderson, E.W., M.W. Sullivan. The Antecedents and Consequences of Customer Satisfaction for Firms // *Marketing Science*, 1993, Vol.12, No. 2, pp. 125-143.
4. Bachman, T. Welcome Back to the Branch // *Bank Marketing*, 2001, Vol. 33, No. 1, Jan/Feb, pp. 40-47.
5. Baker, M.J. Bank Marketing – Myth or Reality? // *The International Journal of Bank Marketing*, 1993, Vol. 11, No. 6.
6. Barich, H., P. Kotler. A Framework for Marketing Image Management // *Sloan Management Review*, 1991, Winter, pp. 94-104.
7. Beckett, A., P. Hewer, B. Howcroft. An Exposition of Consumer Behaviour in the Financial Services Industry // *The International Journal of Bank Marketing*, 2000, Vol. 18, No. 1, pp. 15-26.
8. Bergstrom, A.J., J.M. Bresnahan. How Banks Can Harness the Power of Branding // *US Banker*, 1996, Vol. 106, No. 3, March, pp. 81-82.
9. Berry, L. Service Marketing is Different // *Business*, 1980, May-June, pp. 24-29.
10. Bitner, M.J. Evaluating Service Encounter: The Effects of Physical Surroundings and Employee Responses // *Journal of Marketing*, 1990, Vol. 54, April, pp. 69-82.
11. Bove, L.L., L.W. Johnson. A Customer-service Worker Relationship Model // *International Journal of Service Industry Management*, 2000, Vol. 11, No. 5, pp. 491-511.
12. Butcher, K., B. Sparks, B., F. O'Callaghan. Evaluative and Relational Influences on Service Loyalty // *International Journal of Service Industry Management*, 2001, Vol. 12, No. 3/4, pp. 310-328.
13. Chang, Z.Y., J. Chan, S.L. Leck. (1997). Management of Market Quality for Correspondent Banking Products // *The International Journal of Bank Marketing*, 1997, Vol. 15, No. 1, pp. 32-35.
14. Chong, E., R. Kennedy, C. Riquier. The Difference between Satisfaction and Service Quality // *EMAC Conference Proceedings*, 1997, No. 1, pp. 257-269.
15. Christopher, M., A. Payne, D. Ballantyne. *Relationship Marketing – Bringing Quality, Customer Service and Marketing Together* – Oxford: Butterworth-Heinemann, 1991.
16. Clark, N., H. Peck, A. Payne, M. Christopher. *Relationship Marketing: Towards a New Paradigm*. In A. Payne (Ed.), *Advances in Relationship Marketing* – London: Kogan Page, 1995.
17. Colgate, M., P.J. Danaher. Implementing a Customer Relationship Strategy: The Asymmetric Impact of Poor Versus Excellent Execution // *Journal of the Academy of Marketing Science*, 2000, Vol. 28, No. 3, Summer, pp. 375-387.
18. Colgate, M., M. Norris. Developing a Comprehensive Picture of Service Failure // *International Journal of Service Industry Management*, 2001, Vol. 12, No. 3/4, pp. 215-235.
19. Colgate, M., K. Stewart, R. Kinsella. Customer Defection: A Study of the Student Market in Ireland // *The International Journal of Bank Marketing*, 1996, Vol. 14, No. 3, pp. 23-29.
20. Cronin, J.J., S.A. Taylor. Measuring Service Quality: A Reexamination and Extension // *Journal of Marketing*, 1992, Vol. 56, July, pp. 55-68.
21. Daniell, A. The Myth of Cross-Selling // *American Banker*, 2000, Vol. 165, No. 53, March, pp. 7.
22. Devlin, J.F. Consumer Evaluation and Competitive Advantage in Retail Financial Services: A Research Agenda // *European Journal of Marketing*, 2001, Vol. 35, No. 5/6, pp. 639-661.
23. Dilliman, D.A. *Mail and Telephone Surveys: the Total Design Method*, – A Wiley – Interscience Publication, John Wiley and Sons, 1978.
24. Ennew, C.T., M.R. Binks. The Impact of Service Quality and Service Characteristics on Customer Retention: Small Business and their Banks in the UK // *British Journal of Management*, 1997, Vol. 7, pp. 219-230.
25. Fisher, A. Winning the Battle for Customers // *Journal of Financial Services Marketing*, 2001, Vol. 6, No. 1, September, pp. 77-84.
26. Farquhar, J. Customer Retention in Retail Financial Services: An Employee Perspective // *International Journal of Bank Marketing*, 2004, Vol. 22, No. 2/3, pp. 86-99.
27. Gilmore, R., J.A. Czepiel. *Reconceptualising Loyalty in Economic Exchange Relationships: Are Marketers People?* // Unpublished working paper, Graduate School of Business Administration, New York University, NY, 1987.
28. Gronroos, C. A Service Quality Model and Its Marketing Implications // *European Journal of Marketing*, 1984, Vol. 18, No. 4, pp. 36-44.

29. Grot, J.C., R.T. Dye. Service Quality: Guidelines for Marketers // *Managing Service Quality*, 1999, Vol. 9, No. 5, pp. 337-358.
30. Healy, T.J. Why You Should Retain Your Customers // *America Community Banker*, 1999, Vol. 8, No. 9, September, pp. 22-26.
31. Holliday, K.K. Keeping Close to the Customer // *Bank Marketing*, 1996, Vol. 28, No. 6, pp. 14-19.
32. Hotchkiss, D.A. What Do Your Customers Really Think? // *Bank Marketing*, 1995, Vol. 27, No. 3, March, pp. 13-19.
33. Hull, L. Foreign-owned Banks: Implications for New Zealand's Financial Stability // *Discussion Paper Series*, DP2002/05, 2002.
34. Ioanna, P.D. The Role of Employee Development in Customer Relations: The Case of UK Retail Banks // *Corporate Communication*, 2002, Vol.7, No.1, pp. 62-77.
35. Jones, H., J.D. Farquhar. Contact Management and Customer Loyalty // *Journal of Financial Services Marketing*, 2003, Vol. 8, No. 1, August, pp. 71-78.
36. Jones, T., W. Sasser, W. Why Satisfied Customers Defect // *Harvard Business Review*, 1995, November-December, pp. 88-99.
37. Kasper, H. On Problem Perception, Dissatisfaction, and Brand Loyalty // *Journal of Economic Psychology*, 1998, Vol. 9, September, pp. 387-397.
38. LaBarbera, P.A., D. Mazursky. A Longitudinal Assessment of Customer Satisfaction/Dissatisfaction: The Dynamic Aspect of the Cognitive Process // *Journal of Marketing Research*, 1983, Vol. 20, November, pp. 393-404.
39. Leeds, B. Mystery Shopping' Offers Clues to Quality Service // *Bank Marketing*, 1992, Vol. 24, No. 11, November, pp. 24-27.
40. Lewis, B.R. Service Quality: An International Comparison of Bank Customers' Expectations and Perceptions // *Journal of Marketing Management*, 1991, Vol. 7, pp. 47-62.
41. Lovelock, C.H. Why Marketing Management Needs to be Different for Services. In J.H. Donnelly and W.R. George (Eds.), *Marketing of Services – Chicago, IL: American Marketing Association*, 1981.
42. Loveman, G.W. Employee Satisfaction, Customer Loyalty, and Financial Performance // *Journal of Service Research*, 1998, Vol. 1, No. 1, pp. 18-31.
43. Malhotra, N.K. *Marketing Research: An Application Orientation (3rd ed.) – New Jersey, US: Prentice-Hall, Inc.*, 1999.
44. Marple, M., M. Zimmerman. A Customer Retention Strategy // *Mortgage Banking*, 1999, Vol. 59, No. 11, August, pp. 45-50.
45. Mendzela, E. Managing Customer Risk // *The CPA Journal*, 1999, Vol. 69, No. 6, pp. 56-59.
46. Mohebi, E., E. Hechter. Telemarketing: Faster, Better, Cheaper // *Bank Marketing*, 1993, Vol. 24, No. 3, March, pp. 36-39.
47. Mylonakis, J., Malliaris, P.G., G.J. Siomkos. Marketing-Driven Factors Influencing Savers In The Hellenic Bank Market // *Journal of Applied Business Research*, 1998, Vol. 14, No. 2, Spring, pp. 109-117.
48. Ngu, N.Y., G. LeBlanc. The Mediating Role of Corporate Image on Customers' Retention Decisions: An Investigation in Financial Services // *The International Journal of Bank Marketing*, 1998, Vol. 16, No. 2, pp. 52-65.
49. Noe, J. Regaining Customer Appreciation. *America's Community Banker*, 1996, Vol. 5, No. 4, April, pp. 16-21.
50. Oliver, R.L. Theoretical Bases of Consumer Satisfaction Research: Review Critique and Future Directions. In C.W. Lamb & P.M. Dunne (Eds.), *Theoretical Developments in Marketing – Chicago, IL: AMA*, 1980, pp. 11-14.
51. Oliver, R.L. *Satisfaction: A Behavioural Perspective on the Consumer – New York, NY: Irwin/McGraw-Hill*, 1997.
52. Oliver, R.L. Whence Customer Loyalty? // *Journal of Marketing*, 1999, Vol. 63, Special Issue, pp. 33-44.
53. Parasuraman, A. Reflections on Gaining Competitive Advantage through Customer Value // *Journal of the Academy of Marketing Science*, 1988, Vol. 25, No. 2, pp. 154-161.

54. Parasuraman, A., V. Zeithaml, L. Berry. Reassessment of Expectations as a Comparison Standard in Measuring Service Quality: Implications for Further // Research. *Journal of Marketing*, 1994, Vol. 58, January, pp. 111-124.
55. Price, L.L., E.J. Arnould. Commercial Friendships: Service Provider-Client Relationships in Context // *Journal of Marketing*, 1999, Vol. 63, No. 4, pp. 38-65.
56. Proctor, T. *Essentials of Marketing Research – Great Britain*: Pitman Publishing (A division of Pearson Professional Limited), 1996.
57. Reichheld, F.F. Learning from Customer Defections // *Harvard Business Review*, 1996, March/April, pp. 56-69.
58. Reichheld, F.F. Loyalty-Based Management // *Harvard Business Review*, 1993, March-April, pp. 64-73.
59. Reichheld, F.F., D. Kenny. The Hidden Advantages of Customer Retention // *Journal of Retail Banking*, 1990, Vol. 7, No. 4, pp. 19-23.
60. Reichheld, F.F., W.E. Sasser. Zero Defections: Quality comes to Services // *Harvard Business Review*, 1990, September-October, pp. 105-111.
61. Riggall, J. A New Study: How Newcomers Select Banks // *American Bankers Association Banking Journal*, 1980, (July), pp. 93-94.
62. Rust, R., A. Zahorik. Customer Satisfaction, Customer Retention and Market Share // *Journal of Retailing*, 1993, Vol. 69, No. 2, pp. 193-215.
63. Schriver, S. Customer Loyalty: Going, Going // *American Demographics*, 1997, September, pp. 20-21.
64. Shostack, G.L. Banks Sell Services-Not Things // *Bankers Magazine*, 1997, Vol. 32, pp. 40-45.
65. Siles, M., L.J. Robinson, S.D. Hanson. Does Friendly Service Retain Customers? // *Bank Marketing*, 1994, Vol. 26, No. 1, January, pp. 47-50.
66. Spreng, R.A., S.B. Mackenzie, R.W. Olshavsky. A Reexamination of the Determinants of Consumers' Satisfaction // *Journal of Marketing*, 1996, Vol. 60, July, pp. 15-32.
67. Stum, D., A. Thiry. Building Customer Loyalty // *Training and Development Journal*, 1991, Vol. 45, No. 4, pp. 34-36.
68. Strandvik, T., V. Liljander. Relationship Strenght in Bank Services // in 1994 Research Conference Proceedings, *Relationship Marketing: Theory, Methods and Applications*, Sheth, Jagdish.; Parvatiyar, Atul (eds.), 1994, June 11-13, Atlanta, US.
69. Sweeney, J.C., G.N. Soutar, L.W. Johnson. Retail Service Quality and Perceived Value // *Journal of Retailing and Consumer Services*, 1997, Vol. 4, No. 1, pp. 39-48.
70. Trubik, E., M. Smith. Developing a Model of Customer Defection in Australian Banking Industry // *Managerial Auditing Journal*, 2000, Vol. 15, No. 5, pp. 199-208.
71. Varki, S., M. Colgate. The Role of Price Perceptions in an Integrated Model of Behavioural Intentions // *Journal of Service Research*, 2001, Vol. 3, No. 3, February, pp. 232-241.
72. Woodruff, R.B. Customer Value: The Next Source of Competitive Advantage // *Journal of Academy of Marketing Science*, 1997, Vol. 25, No. 2, pp. 139-153.