





# “The moderating role of IFRS in the relationship between risk management and financial disclosure in Jordanian banks”

<b>AUTHORS</b>	Qasim Ahmad Alawaqleh  Mohammad Hamdan  Ahmed Al-Jayousi  Rana Airout 
<b>ARTICLE INFO</b>	Qasim Ahmad Alawaqleh, Mohammad Hamdan, Ahmed Al-Jayousi and Rana Airout (2022). The moderating role of IFRS in the relationship between risk management and financial disclosure in Jordanian banks. <i>Banks and Bank Systems</i> , 17(3), 167-176. doi: <a href="https://doi.org/10.21511/bbs.17(3).2022.14">10.21511/bbs.17(3).2022.14</a>
<b>DOI</b>	<a href="http://dx.doi.org/10.21511/bbs.17(3).2022.14">http://dx.doi.org/10.21511/bbs.17(3).2022.14</a>
<b>RELEASED ON</b>	Monday, 26 September 2022
<b>RECEIVED ON</b>	Sunday, 13 February 2022
<b>ACCEPTED ON</b>	Friday, 02 September 2022
<b>LICENSE</b>	 This work is licensed under a <a href="https://creativecommons.org/licenses/by/4.0/">Creative Commons Attribution 4.0 International License</a>
<b>JOURNAL</b>	"Banks and Bank Systems"
<b>ISSN PRINT</b>	1816-7403
<b>ISSN ONLINE</b>	1991-7074
<b>PUBLISHER</b>	LLC “Consulting Publishing Company “Business Perspectives”
<b>FOUNDER</b>	LLC “Consulting Publishing Company “Business Perspectives”



NUMBER OF REFERENCES

**32**



NUMBER OF FIGURES

**2**



NUMBER OF TABLES

**4**

© The author(s) 2022. This publication is an open access article.



## BUSINESS PERSPECTIVES



LLC "CPC "Business Perspectives"  
Hryhorii Skovoroda lane, 10,  
Sumy, 40022, Ukraine  
[www.businessperspectives.org](http://www.businessperspectives.org)

**Received on:** 13<sup>th</sup> of February, 2022  
**Accepted on:** 2<sup>nd</sup> of September, 2022  
**Published on:** 26<sup>th</sup> of September, 2022

© Qasim Alawaqleh, Mohammad Hamdan, Ahmed Al-Jayousi, Rana Airout, 2022

Accounting, Philadelphia University, Jordan. (Corresponding author)

Mohammad Hamdan, Ph.D., Lecturer, Faculty of Business, Department of Accounting, Philadelphia University, Jordan.

Ahmed Al-Jayousi, Ph.D., Professor, Faculty of Business, Finance Department, Philadelphia University, Jordan.

Rana Airout, Ph.D., Assistant Professor, Faculty of Business, Department of Accounting, Philadelphia University, Jordan.



This is an Open Access article, distributed under the terms of the [Creative Commons Attribution 4.0 International license](https://creativecommons.org/licenses/by/4.0/), which permits unrestricted re-use, distribution, and reproduction in any medium, provided the original work is properly cited.



**Conflict of interest statement:**  
Author(s) reported no conflict of interest

Qasim Alawaqleh (Jordan), Mohammad Hamdan (Jordan), Ahmed Al-Jayousi (Jordan), Rana Airout (Jordan)

# THE MODERATING ROLE OF IFRS IN THE RELATIONSHIP BETWEEN RISK MANAGEMENT AND FINANCIAL DISCLOSURE IN JORDANIAN BANKS

## Abstract

This study investigated the impact of IFRS on the relationship between risk management and financial disclosure in Jordanian banks in light of the Covid-19 pandemic. The study data were collected from Jordanian banks' financial reports with the help of panel data to measure IFRS and risk management. The study depended on daily data, at a rate of (256) trading days from March 3, 2020 until April 29, 2021. Also, the study used questionnaires to measure financial disclosure in addition to interviews with eight Jordanian bank managers. Multiple regression was used to test hypotheses. The study found a positive statistically significant relationship between risk management and financial disclosure. The relationship was portrayed by a coefficient of 0.315. The result also showed the moderating role of IFRS in such a relationship, the effect reached 0.696. The conclusions have implications for both theory and practice. In fact, the findings elucidated the connection between risk management, IFRS, and financial disclosure. Finally, Jordanian banks should focus on IFRS and risk management, enhanced management, and employee skills as recommendations in this study. Thus, Jordanian banks pay particular attention to IFRS and risk management in order to achieve profitability through financial disclosure.

## Keywords

risk management, International Financial Reporting Standards, fiscal disclosure

## JEL Classification

G21, G32, M41

## INTRODUCTION

This study depended on financial statements that are comparable and of high-quality to measure some of study variables in agreement with Lev (2018). The researchers achieved significant progress in this study due to the harmonization and convergence of IFRS because Jordanian banks depend on them in financial analysis and financial disclosure (Tschopp & Nastanski, 2014). According to Jordanian corporate governance, Jordanian banks use IFRS, and this caused the researchers to have high confidence while testing hypotheses and measuring variables in this study (Acosta et al., 2019).

On the other hand, risk disclosure includes release of both financial and non-financial information about a company's material risks and how they are likely to affect its current and future performance (Campbell et al., 2014). The worldwide financial crises of 2007–2009 sparked widespread concern about excessive risk-taking by public corporations, research into disclosure and risk management, and regulatory measures by accounting regulation observers and public bodies. Risk disclosure is information that highlights the significant risks faced by businesses and the estimated economic impact these risks will

have on both the present and future outcomes (Admati, 2017). Jordanian banks are not far about financial crises; Jordan is a part of the world; besides, Jordan is still facing economic problems. The current situation in Jordan aroused the interest of researchers in this study. The global financial crises of 2007–2009 have greatly increased public concern on the daring risk-taking activities by public companies, research interest in disclosure and risk management globally. They have necessitated changes in regulations from various accounting regulators and government agencies to address these concerns, among other things. Corporate risk disclosure is now a key component of business disclosure, according to prior research by scholars such as Camilleri (2018), Harper Ho (2018), and Manes-Rossi et al. (2018), because it provides greater transparency and increases investor confidence in developed markets and countries. According to Anton (2018) and Yang et al. (2018), companies facing stock price volatility and financial difficulties are more likely to use enterprise risk management (ERM) and disclose their financial risks. However, there is little empirical evidence regarding financial risk disclosure in emerging nations.

## 1. LITERATURE REVIEW

The literature of this study includes the discussion of Risk management as an independent variable, financial disclosure as a dependent variable, and Moderating variable role of IFRS, in addition to a Summary of the literature.

### 1.1. Risk management

Sadgrove (2016) defines risk as the probability of suffering a loss and becoming a casualty. According to Rausand (2013), risk is the possibility of an error, the probability that an event will occur or not occur; these descriptions all point in the same direction (loss or mishap). This study defines risk as the probability of financial loss. Effective enterprise risk management (ERM) has become a critical, if not primary, responsibility for businesses (Saardchom, 2013). Risk-taking organizations that manage risks effectively are more likely to accomplish or surpass their goals (Stulz, 2014). Risk can be interpreted in two ways: as an opportunity or a threat. Historically, companies have taken a defensive stance toward risks, regarding them as situations to be avoided or mitigated.

Today, risk management practice has undergone a sea change. Historically, businesses managed risk in “silos”, with distinct organizational units managing different forms of risk – strategic, business, credit, market, and operational (Maingot et al., 2018). Risk management specialists have long recognized that risks are intrinsically interrelated and interdependent. For example, major business disasters are often the result of the convergence of multiple risk factors. This new approach evaluates all risks holisti-

cally through the lens of ERM (Maingot et al., 2018). While there is no universally standardized approach to risk management, there is widespread agreement that ERM should be incorporated throughout the business. This provides a context for risk management and engages a broader segment of a company in an integrated approach.

Businesses must integrate risk management and corporate governance (Shad et al., 2019). This requires collaboration between risk owners, directors, external and internal auditors, and senior management. What is the board’s proper role in enterprise risk management? Atwijuka and Caldwell (2017) assert that traditional models imply that boards cannot and should not be involved in day-to-day risk management. Rather than that, directors should be able to convince themselves that appropriate risk management mechanisms are in place and performing successfully through their risk monitoring responsibility. The risk management system should enable management to notify the board about material risks. However, Atwijuka and Caldwell (2017) argue that boards must play a more active and direct role in ERM, going beyond traditional oversight of traditional risk management systems.

McShane (2018) previously highlighted this argument, highlighting that the director’s duty includes challenging management to ensure that risk is fully incorporated during the strategic and business planning processes. Recent complaints have alleged that board members lack awareness of the corporation’s material issues (Admati, 2017). These board members should receive board training and tutorials. A Framework for Board Oversight of Enterprise Risk (Atwijuka & Caldwell, 2017) of the

CICA focuses primarily on the board's risk oversight role, giving essential guidelines and tools to assist directors in carrying out their obligations. Corporate governance is a component of ERM. ICs operate on a smaller scale within the organization, frequently overlooking the strategic objectives of ERM. In general, the risks in banks are linked to financial losses, these are risks of a financial nature such as liquidity risk, credit risk, bank portfolio interest rate risk, and market risk. Risk is a part of the bank's work, to achieve returns for its owners, it must bear some risks.

Today Jordanian banks encounter a real crisis because of Covid-19, which negatively affected their financial performance. The researchers interviewed eight Jordanian bank managers. The banks' managers disclosed that Covid-19 was the greatest risk to their financial performance. This problem affects Jordanian banks' financial disclosure to investors because of the reduction in profitability.

## 1.2. Financial disclosure

Setiany et al. (2017) asserted that the voluntary financial disclosure is a form of financial information revealed to the public in a financial report provided voluntarily and without any duty to do so. Doni et al. (2019) showed that the voluntary financial disclosure is when a corporation discloses more financial information beyond what is required by law. Or, to put it another way, this information is not required to be revealed, yet a corporation nonetheless disclosed it. According to this result, voluntary financial disclosure is financial information that a corporation publishes to expand the disclosure of mandated financial information. Manes-Rossi et al. (2018) state that financial disclosure is essential for communication with interested parties because it can provide an overview of a company's prospects, enhance governance structure, and expand investor protection. Also, the study confirmed that the voluntary financial disclosure reduces the information asymmetry between a company, its investors, and other interested parties. According to Jackson et al. (2020), voluntary financial disclosure plays a significant role in growing trust for the business, and a thorough examination of its practice is necessary.

Meek et al. (1995) appeared that the strategies used to determine voluntary financial disclosure items, which are bits of data that a corporation willingly discloses, this case applied by Jordanian banks, which disclosed about financial statements in Amman Stock Exchange, and this study depended on these disclosures in collecting data. Meek et al. (1995) studied one hundred and twenty-eight potential voluntary financial disclosure items from a range of annual reports of corporations and other financial institutions, as well as all the necessary guidelines on what data must be released, such as SEC rules, public standards, private standards, AICPA booklet, and exchange guidelines of other countries. After that, the researchers recommend all prospective voluntary financial disclosure items are matched to mandated disclosure items and re-identified. Meek et al. (1995) did not address the needs of market analysts and investors when identifying disclosure items (pieces of information released by a corporation). Researchers confirmed this dilemma during the interview with Jordanian bank managers. As a result, the disclosure items gathered by Meek et al. (1995) are used in this study. Using the findings of Meek et al. (1995) as a guide, this study will develop items that are essential in the financial sector as a measure of voluntary financial disclosure, after adjustments with disclosure obligation items, that companies are required to disclose for public companies in Jordan. This procedure is carried out to guarantee that the disclosure items provided are appropriate for the Jordanian business environment.

## 1.3. Moderating role of IFRS

Othman and Kossentini (2015) found that implementing the International Financial Reporting Standards (IFRS) is one of the tactics for standard-setting adopted in many emerging markets. Several empirical studies have been conducted to determine the applicability of IFRS among countries in South Asia (Ahmed & Ali, 2015). Ahmed and Ali (2015) went into greater detail on how accounting harmonization has improved across India, Pakistan, and Bangladesh and why this is the case. Furthermore, according to Datta et al. (2021), only implementing the International Financial Reporting Standards (IFRS) will improve India's quality of financial information. This development may occur due to these countries' unbiased and high-quality data.

On the other hand, Alawaqleh (2020) asserted that the application of IFRS in Jordanian industrial companies had a positive relationship with accounting information quality. Thus, the knowledge asymmetry challenge among investors can, to some extent, be alleviated. For example, International Accounting Standard 38 (intangible assets) of the International Financial Reporting Standards (IFRS) precisely established how intangible assets are recognized initially and later. Intangible assets should be valued at their current market value during acquisition.

Furthermore, the cost or revaluation models can be employed in the future if necessary. As a result, IFRS provides distinct recommendations for measuring assets and liabilities. As a result, implementing IFRS may aid in reducing information asymmetry by providing neutral and high-quality financial information. First, IFRS adoption results in a unique set of unbiased financial information necessary for strengthening conditional accounting conservatism (Datta et al., 2021). The second reason is that implementing IFRS results in high-quality financial information (Datta et al., 2021). Second, the influence of IFRS adoption may cause a positive association between risk management and financial disclosure to revert to a negative relationship.

According to the above discussion, the researchers summarize the literature as follows: Various changes have occurred over time in risk management and financial disclosure. From the literature review, it is observed that risk management has greatly transformed from the old management systems where businesses managed risk in “silos”, with distinct units managing various forms of risk, to a more intrinsically interrelated system that recognizes risks as a convergence of multiple factors that need to be approached and evaluated holistically through the lens of ERM. It is observed that Jordanian banks have encountered a crisis as a result of the Covid-19 pandemic, which negatively affected financial performance within the entire sector. According to the interviews, Jordanian bank managers revealed that the Covid-19 was a major risk to the financial performance of banks, leading to limited financial disclosures to investors. From the above literature review, it

is established that IFRS synchronizes accounting standards across the banking sector, thus significantly reducing information asymmetry. Therefore, this study aims to present the impact of IFRS on the relationship between risk management and financial disclosure in Jordanian banks in light of the Covid-19 pandemic.

Further, this study aimed to analyze the relationship between risk management, IFRS, and Jordanian banks' financial disclosures in light of Covid-19.

Based on the literature review, the following hypotheses were formulated:

*H1: Risk management positively affects the Jordanian banks' voluntary financial disclosure.*

*H2: The relationship between risk management and financial disclosure is moderated by IFRS adoption.*

## 2. METHODS

Multiple regressions were performed in the study to test the outlined hypotheses. The study used a quantitative approach with panel data to establish the relationship between the variables.

The data were collected from 24 banks listed on the Amman Stock Exchange. The researchers depended on daily study data, at a rate of (256) trading days for the Jordanian Stock Exchange from March 3, 2020, until April 29, 2021. On the other hand, based on the study by Muayed and Abbas (2020), a questionnaire was designed to measure financial disclosure and distributed to bank managers, financial managers, and accountants. The total number of circulated questionnaires was 120. One hundred and twelve questionnaires were analyzed, whereas eight were not valid for analysis.

In light of the former hypotheses, the theoretical framework consists of the predictor variable represented by risk management, the response variable represented by financial disclosure in banks listed on Amman Stock Exchange, and the moderating variable represented by IFRS.

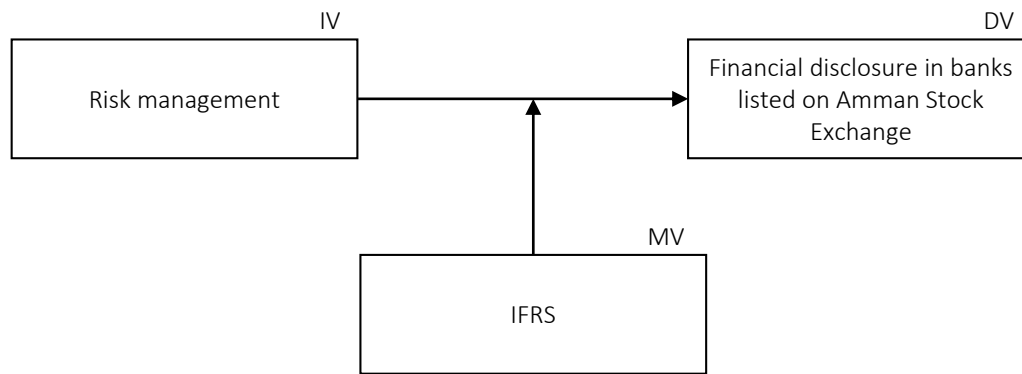

**Figure 1.** Model of the study

The model is relevant in light of the variables at hand to clarify and explain the moderating role of IFRS on the relationship between risk management and Jordanian banks' financial disclosure. Accordingly, the study model was established (see Figure 1).

The ( $\beta$ ) coefficient of the regression indicates the influence of the predictor variable (Risk management) on the response variable (Financial disclosure in banks listed on the Amman stock exchange) and the effect of the moderating variable (IFRS) on the independent variable-dependent variable relationship. As a single unit change in the independent variable is expected to produce a relative change in the  $\beta$  coefficient of the dependent variable, every single unit change in the moderating variable is also expected to produce a relative effect on the size of  $\beta$  in the relationship between the independent and the dependent variable.

### 3. RESULTS

In line with that, the study showed the following results of the normality data; as shown in Table 1, the normality distribution for the dependent variables was adequate. This study's findings revealed that the Skewness and Kurtosis for the two variables are all less than a factor of two. As a result, the statistical community declares the data to be regularly distributed. On the other hand, the researchers were able to aid in the normality result by employing a histogram graph, which is often used to evaluate data normality in statistical analyses. Figuring out how near to the "bell curve" a

dependent variable's distributions may be, Figure 1 successfully demonstrated that the normalcy requirement for financial disclosure was met. Take a look at the histogram distributions for these two variables in the following (see Figure 2).

**Table 1.** Normality result

Descriptive statistics		
Variable	Skewness	Kurtosis
Risk management	-1.038	-.365
IFRS	-.316	.563

In relation to the descriptive analysis and according to the sample study, the respondents were 15 bank managers by 0.13, 21 financial managers by 0.19, and 76 accountants by 0.68.

A multicollinearity test was used; multiple linear correlations were tested to determine whether the study model was suitable for linear regression analysis. Multicollinearity inflates the coefficient of determination  $R^2$ , making it more significant than its actual value. The value of the coefficient of determination was calculated to determine whether or not the study model was suitable for linear regression analysis. According to the study model, the following variables had the following effects on the outcome (see Table 2).

**Table 2.** Multicollinearity test

Variable	Risk management	IFRS	Financial disclosure
Risk management	1	-	-
IFRS	-.038	1	-
Financial disclosure	.104	.066	1

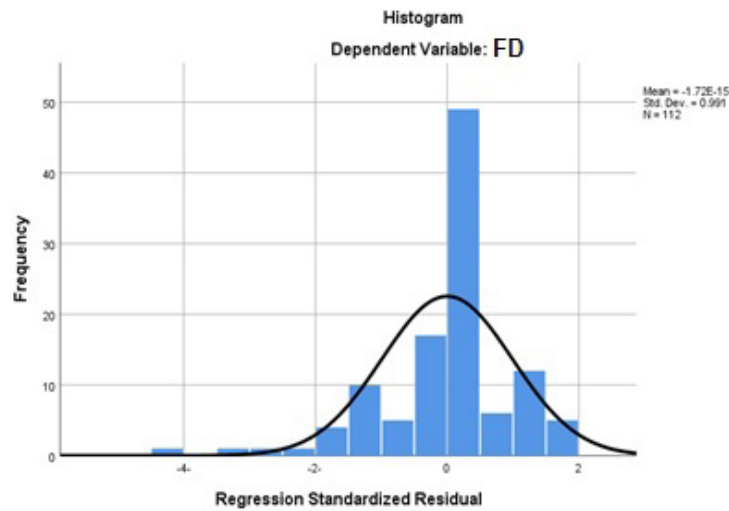

**Figure 2.** Regression standardized residual

Table 2 demonstrates that the maximum correlation coefficient was found between the two variables (Risk management and financial disclosure), which reached 0.104, which is less than 0.80, indicating that the phenomenon of multicollinearity between the variables was not present. On the other hand, the correlation coefficient is greater than 0.80, which shows the presence of the numerous high linear correlation problem, which is more common than it should be (Guajarati, 2004).

According to the interviews conducted by researchers, eight bank managers confirmed that during the Covid-19, the banks suffered from financial distress due to closed borders between countries, which led to reduced trading activities among citizens leading to the closure of Jordanian banks. Also, the study survey results related to the questionnaire showed how the banks were doing during Covid-19 in terms of financial disclosure, which is positive related to risk management in Jordanian banks. The relationship was 0.315. The researchers used the following statistical meth-

ods to find answers to the study’s questions and achieve its objectives:

### 3.1. Multiple regression coefficients

Multiple regressions were used to test the hypotheses and explain the research findings. The coefficients table was used to test the hypotheses in this study (Table 3).

Moreover, the study confirmed the result of the effect of moderating variable (IFRS) on the relationship between IV (risk management) and DV (financial disclosure). The result appears in Table 4

## 4. DISCUSSION

As shown in Table 3,  $R^2 = 0.170$ , which means that risk management has explained (17%) of variance in financial disclosure, while other factors remained constant. It also confirmed that risk management affects financial disclosure ( $\beta$

**Table 3.** Coefficients

Variable	Standardized coefficients Beta	T	Sig.
(Constant)	3.478	5.325	0.000
Risk management	0.315	4.125	0.000
R	0.197	–	–
R2	0.170	–	–
Adjusted R2	0.165	–	–
F value	31.465	–	0.000

Note: Dependent variable (FD).

**Table 4.** Moderating analysis

Model	Variable	R-Square	F	Sig.	Beta	T	Sig.
1	(Constant)	–	–	–	–	6.331	0.000
	Risk management	0.550	385.002	0.000	0.628	16.382	0.000
2	(Constant)	–	–	–	–	6.282	0.000
	Risk management	0.528	235.319	0.000	0.656	21.528	0.000
	IFRS	–	–	–	0.165	3.385	0.003
3	(Constant)	–	–	–	–	6.540	0.000
	Risk management	0.696	652.479	0.000	0.190	3.021	0.036
	IFRS	–	–	–	1.965	3.014	0.000
IFRS · Risk management		–	–	–	1.572	7.865	0.000

Note: Dependent variable: financial disclosure.

= 0.315,  $t = 4.125$ ,  $p < 0.01$ ). However, the findings indicate that risk management affects financial disclosure. This means that  $H1$  is supported. As asserted by Noja et al. (2021), a corporate governance committee is positively related to the size of a company (Assets) with financial risk management for all the links with indicators of company profitability and financial performance. These findings propose that the bigger the financial disclosure in the banks is, the better the financial risk management. Also, corporate governance strategies in Jordan support and confess risk management disclosure. Jia et al. (2019) confirmed this result during the independent risk management committees, which is positively linked with risk management disclosure quality. On the other hand, there is no high association between risk management disclosure quality and the independence of risk management committees. In addition, strategies and policies of Jordan central bank in terms of corporate government always support financial performance and firm profitability of banks, especially during the Covid-19 pandemic, and disclose the financial risk management in Jordanian banks.

In addition, the results of examining the moderating effects of IFRS on the relationship between risk management and financial disclosure are shown in Table 4. As a result, F-tests for models 1, 2, and 3 have large values, and the p-value for the F-test for each model is less than 0.05. Risk management significantly affected financial disclosure in the first model ( $t = 16.382$ ,  $p = 0.000$ ). When the IFRS is added in model 2, there is a substantial relationship between the IFRS ( $t$ -test

=  $-3.385$ , p-value 0.05) and risk management ( $t$ -test =  $21.528$ ,  $p = 0.000$ ). Risk management and IFRS were also elements that influenced financial disclosure in Model 3. This model discovered that when IFRS interacts with risk management, the interaction has a major impact on financial disclosure. The interaction changed the extent to which the link between risk management and financial disclosure was adjusted and the direction of the relationship. With a value of 0.696, R-square for Model 3 is greater than that of Models 1 and 2, indicating that the interaction between IFRS and risk management accounts for 69.6 % of the variability in financial disclosure. According to the findings, the interaction term is significant, and IFRS has a moderating effect on the effects of risk management on financial disclosure. Surprisingly, considerable evidence shows that the IFRS moderates the relationship between risk management and financial disclosure. As a result,  $H2$  is supported.

From the study results, the use of international financial reporting standards has a favorable link with financial disclosure because it maximizes financial disclosure. These results are consistent with the findings of Anton (2018), Atwijuka (2017), Camilleri (2018), Campbell (2014), Daniswara (2021), Datta (2021), and Doni (2019). Many researchers favor the implementation of IFRS because they feel that using these standards at the worldwide level increases the quality of financial reports and statements and the comparability of organizations on the local and international level. It also helps to attract foreign money and achieve the best possible integration of capital markets (Othman, 2015).



## CONCLUSION

The goal of this study was to analyze the relationship between risk management, IFRS, and the financial disclosure of Jordanian banks in light of the Covid-19 pandemic. Literature study, alongside primary and secondary data, were used to generate data for analysis of variables. The study's findings revealed a significant relationship between risk management and financial disclosure, with a coefficient of 0.315. In addition, it was discovered that IFRS plays a vital role in moderating the relationship between risk management and financial disclosure. Therefore, the two hypotheses hold, and it was concluded that:

- a) Risk management positively affects voluntary financial disclosure by Jordanian banks; and
- b) The relationship between risk management and financial disclosure is moderated by IFRS adoption.

The conclusions have implications for both theory and practice. The findings contribute to theory by elucidating the link between risk management, IFRS, and financial disclosure. Despite the convergence of the relationship between corporate governance and organizational performance, few studies have looked at IFRS as a moderating variable, particularly in the financial sector in developing countries. Another contribution is the two-pronged approach, which involves a comprehensive review of the literature and analyzing actual data derived from Jordanian banks.

In terms of practical ramifications, the findings supported empirical findings of factors influencing financial disclosure – an important discovery for management and policy-makers. Moving on to the study's shortcomings, which future research can address: First, the data employed in the study is local-based, representing just local banks, necessitating cautious generalization to adoption behavior in other nations' financial sectors. Following an original empirical approach based on SPSS, the study attempted to summarize the decisive importance of IFRS and risk management, enhanced management, and employee skills as recommendations for Jordanian banks. The IFRS and risk management in Jordanian banks were particularly grasped as being strongly related to the financial disclosure to achieve profitability. The IFRS and risk management accounted for their power, connecting the financial disclosure measures in Jordanian banks. The results portray IFRS and financial risk management as positively related to financial performance of Jordanian banks. In this perspective, positive financial disclosure results will strengthen investors' confidence in the activity and operation of the considered banks. Finally, the policy modulations of study outcomes relate to the recommendation for Jordanian banks to set and follow rules of regulations and corporate governance, through the entity of a highly-skilled, active and independent risk management board, with suitable responsibilities and tasks, policies, and pure objectives agree with Jordanian banks, in addition, to take the IFRS into account. The study also has limitations regarding the study factors evaluated, which may be addressed in future studies by thoroughly assessing the model from other perspectives.

## AUTHOR CONTRIBUTIONS

Conceptualization: Qasim Alawaqleh, Mohammad Hamdan, Ahmed Al-Jayousi, Rana Airout.

Data curation: Qasim Alawaqleh, Mohammad Hamdan, Ahmed Al-Jayousi, Rana Airout.

Formal analysis: Qasim Alawaqleh, Mohammad Hamdan, Ahmed Al-Jayousi, Rana Airout.

Investigation: Qasim Alawaqleh, Mohammad Hamdan, Ahmed Al-Jayousi, Rana Airout.

Methodology: Qasim Alawaqleh, Mohammad Hamdan, Ahmed Al-Jayousi, Rana Airout.

Project administration: Qasim Alawaqleh, Mohammad Hamdan, Ahmed Al-Jayousi, Rana Airout.

Validation: Qasim Alawaqleh, Mohammad Hamdan, Ahmed Al-Jayousi, Rana Airout.

Writing – original draft: Qasim Alawaqleh, Mohammad Hamdan, Ahmed Al-Jayousi, Rana Airout.

Writing – reviewing & editing: Qasim Alawaqleh, Mohammad Hamdan, Ahmed Al-Jayousi, Rana Airout.

## ACKNOWLEDGMENT

The publication of this research has been supported by the Deanship of Scientific Research and Graduate Studies at Philadelphia University – Jordan.

## REFERENCES

- Acosta, L. E. R., Mayorga, D. A. C., & García, O. C. (2019). Effect of convergence to International Financial Reporting Standards on Companies Listed in the Colombian Stock Exchange. *AD-Minister*, 35, 77-92. <https://doi.org/10.17230/Ad-minister.35.3>
- Admati, A. R. (2017). A skeptical view of financialized corporate governance. *Journal of Economic Perspectives*, 31(3), 131-150. <https://doi.org/10.1257/jep.31.3.131>
- Ahmed, K., & Ali, M. J. (2015). Has the harmonisation of accounting practices improved? Evidence from South Asia. *International Journal of Accounting Information Management*, 23(4), 327-348. <https://doi.org/10.1108/IJAIM-12-2014-0082>
- Alawaqleh, Q. A. (2020). Relationship between the application of IFRS and the accounting information quality in Jordan. *Investment Management and Financial Innovations*, 17(4), 111-120. [http://dx.doi.org/10.21511/imfi.17\(4\).2020.11](http://dx.doi.org/10.21511/imfi.17(4).2020.11)
- Anton, S. G. (2018). The impact of enterprise risk management on firm value: Empirical evidence from Romanian non-financial firms. *Engineering Economics*, 29(2), 151-157. <https://doi.org/10.5755/j01.ee.29.2.16426>
- Atwijuka, S., & Caldwell, C. (2017). Authentic leadership and the ethic of care. *Journal of Management Development*, 36(8), 1040-1051. <https://doi.org/10.1108/JMD-12-2016-0331>
- Camilleri, M. A. (2018). Theoretical insights on integrated reporting: The inclusion of non-financial capitals in corporate disclosures. *Corporate Communications: An International Journal*, 23(4), 567-581. <https://doi.org/10.1108/CCIJ-01-2018-0016>
- Campbell, J. L., Chen, H., Dhaliwal, D. S., Lu, H.-m., & Steele, L. B. (2014). The information content of mandatory risk factor disclosures in corporate filings. *Review of Accounting Studies*, 19(1), 396-455. <https://doi.org/10.1007/s11142-013-9258-3>
- Daniswara, Y. (2021). *Pengaruh Keragaman Dewan, Koneksi Politik, Dan Kepemilikan Asing Terhadap Kualitas Pengungkapan Corporate Social Responsibility (CSR)*. Universitas Airlangga.
- Datta, J., Monsur, M. B., Chakraborty, P., Chakrabarty, S., Fahad, S., Hossain, A., Mondal, Md F, Ahmed, S., Ali, Md P, & Sabagh, A. (2021). Obstacle in controlling major rice pests in Asia: insecticide resistance and the mechanisms to confer insecticide resistance. In S. Fahad, O. Sönmez, S. Saud, D. Wang, C. Wu, M. Adnan, M. Arif, and Amanullah (Eds.), *Engineering tolerance in crop plants against abiotic stress*. CRC Press. <http://dx.doi.org/10.1201/9781003160717-5>
- Doni, F., Martini, S. B., Corvino, A., & Mazzoni, M. (2019). Voluntary versus mandatory non-financial disclosure: EU Directive 95/2014 and sustainability reporting practices based on empirical evidence from Italy. *Meditari Accountancy Research*, 28(5), 781-802. <https://doi.org/10.1108/ME-DAR-12-2018-0423>
- Guajarati, D. (2004). *Econometria (Cuarta)*. México DF: McGraw-Hill Interamericana.
- Harper Ho, V. (2018). Nonfinancial risk disclosure and the costs of private ordering. *American Business Law Journal*, 55(3), 407-474. <https://doi.org/10.1111/ablj.12123>
- Jackson, G., Bartosch, J., Avetisyan, E., Kinderman, D., & Knudsen, J. S. (2020). Mandatory non-financial disclosure and its influence on CSR: An international comparison. *Journal of Business Ethics*, 162(2), 323-342. <https://doi.org/10.1007/s10551-019-04200-0>
- Jia, J., Li, Z., & Munro, L. (2019). Risk management committee and risk management disclosure: evidence from Australia. *Pacific Accounting Review*, 31(3), 438-461. <https://doi.org/10.1108/PAR-11-2018-0097>
- Lev, B. (2018). The deteriorating usefulness of financial report information and how to reverse it. *Accounting and Business Research*, 48(5), 465-493. <https://doi.org/10.1080/00014788.2018.1470138>
- Maingot, M., Quon, T., & Zéghal, D. (2018). Risk management by US and Canadian financial firms during the financial crisis. *International Journal of Disclosure Governance*, 15(4), 221-234. <https://doi.org/10.1057/s41310-018-0049-8>
- Manes-Rossi, F., Tiron-Tudor, A., Nicolò, G., & Zanellato, G. (2018). Ensuring more sustainable reporting in Europe using non-financial disclosure – De facto and de jure evidence. *Sustainability*, 10(4), 1162. <https://doi.org/10.3390/su10041162>
- McShane, M. (2018). Enterprise risk management: history and a design science proposal. *The Journal of Risk Finance*, 19(2), 137-153. <https://doi.org/10.1108/JRF-03-2017-0048>
- Meek, G. K., Roberts, C. B., & Gray, S. J. (1995). Factors influencing voluntary annual

- report disclosures by US, UK and continental European multinational corporations. *Journal of International Business Studies*, 26(3), 555-572. <https://doi.org/10.1057/palgrave.jibs.8490186>
21. Muayed, A. H. Al F., & Abbas, F. A. (2020). Measurement and accounting disclosure of financial derivatives and its impact on the preparation of financial statements. *The Islamic College University Journal*, 1(66), 329-352. Retrieved from <https://www.iasj.net/iasj/article/236629>
  22. Noja, G. G., Thalassinos, E., Cristea, M., & Gresu, I. M. (2021). The Interplay between Board Characteristics, Financial Performance, and Risk Management Disclosure in the Financial Services Sector: New Empirical Evidence from Europe. *Journal of Risk and Financial Mnagement*, 14(2), 79. <https://doi.org/10.3390/jrfm14020079>
  23. Othman, H. B., & Kossentini, A. (2015). IFRS adoption strategies and theories of economic development: Effects on the development of emerging stock markets. *Journal of Accounting in Emerging Economies*, 5(1), 70-121. <https://doi.org/10.1108/JAEE-02-2012-0006>
  24. Qndor, A. A. (2020). Banking risks and their measurement methods. *Studies of the Training and Capacity Building Institute*, 5. Arab Monetary Fund.
  25. Rausand, M. (2013). *Risk assessment: theory, methods, and applications* (Vol. 115). John Wiley & Sons.
  26. Saardchom, N. (2013). Enterprise risk management under sustainability platform. *Journal of Business Economics*, 4(1), 32-41. Retrieved from <http://www.academicstar.us/UploadFile/Picture/2014-6/2014615104327304.pdf>
  27. Sadgrove, K. (2016). *The complete guide to business risk management*. Routledge.
  28. Setiany, E., Hartoko, S., Suhardjanto, D., & Honggowati, S. (2017). Audit committee characteristics and voluntary financial disclosure. *Review of Integrative Business Economics Research*, 6(3), 239-253. Retrieved from <https://repository.feb.uns.ac.id/dok/publikasi/1015.pdf>
  29. Shad, M. K., Lai, F.-W., Fatt, C. L., Klemeš, J. J., & Bokhari, A. (2019). Integrating sustainability reporting into enterprise risk management and its relationship with business performance: A conceptual framework. *Journal of Cleaner Production*, 208, 415-425. Retrieved from <https://doi.org/10.1016/j.jclepro.2018.10.120>
  30. Stulz, R. M. (2014). *Governance, risk management, and risk-taking in banks* (Working Paper No. 20274). Retrieved from <https://www.nber.org/papers/w20274>
  31. Tschopp, D., & Nastanski, M. (2014). The Harmonization and Convergence of Corporate Social Responsibility Reporting Standards. *Journal of Business Ethics*, 125(1), 147-162. <https://doi.org/10.1007/s10551-013-1906-9>
  32. Yang, S., Ishtiaq, M., & Anwar, M. (2018). Enterprise risk management practices and firm performance, the mediating role of competitive advantage and the moderating role of financial literacy. *Journal of Risk Financial Management*, 11(3), 35. <https://doi.org/10.3390/jrfm11030035>