



“Economic security in investment projects management: convergence of accounting mechanisms”

| | |
|---------------------|---|
| AUTHORS | Nataliia Ostapiuk Oleksandra Karmaza  https://orcid.org/0000-0003-4895-5220 Mykola Kurylo  https://orcid.org/0000-0003-1496-134X Gennady Timchenko |
| ARTICLE INFO | Nataliia Ostapiuk, Oleksandra Karmaza, Mykola Kurylo and Gennady Timchenko (2017). Economic security in investment projects management: convergence of accounting mechanisms. <i>Investment Management and Financial Innovations</i> , 14(3), 353-360. doi: 10.21511/imfi.14(3-2).2017.06 |
| DOI | http://dx.doi.org/10.21511/imfi.14(3-2).2017.06 |
| RELEASED ON | Tuesday, 28 November 2017 |
| RECEIVED ON | Thursday, 26 October 2017 |
| ACCEPTED ON | Friday, 10 November 2017 |
| LICENSE |  This work is licensed under a Creative Commons Attribution 4.0 International License |
| JOURNAL | "Investment Management and Financial Innovations" |
| ISSN PRINT | 1810-4967 |
| ISSN ONLINE | 1812-9358 |
| PUBLISHER | LLC “Consulting Publishing Company “Business Perspectives” |
| FOUNDER | LLC “Consulting Publishing Company “Business Perspectives” |



NUMBER OF REFERENCES

11



NUMBER OF FIGURES

3



NUMBER OF TABLES

2

© The author(s) 2022. This publication is an open access article.



BUSINESS PERSPECTIVES



LLC "CPC "Business Perspectives"
Hryhorii Skovoroda lane, 10, Sumy,
40022, Ukraine

www.businessperspectives.org

Received on: 26th of October, 2017

Accepted on: 10th of November, 2017

© Nataliia Ostapiuk, Oleksandra Karmaza, Mykola Kurylo, Gennady Timchenko, 2017

Nataliia Ostapiuk, Ph.D. (Economics), Professor, Kyiv National Economic University named after Vadym Hetman, Ukraine.

Oleksandra Karmaza, Ph.D. (Law), Associate Professor, University of Modern Knowledge, Ukraine.

Mykola Kurylo, Ph.D. (Law), Sumy National Agrarian University, Ukraine.

Gennady Timchenko, Ph.D. (Law), V. M. Koretsky Institute of State and Law of National Academy of Sciences of Ukraine, Ukraine.



This is an Open Access article, distributed under the terms of the [Creative Commons Attribution 4.0 International license](https://creativecommons.org/licenses/by/4.0/), which permits unrestricted re-use, distribution, and reproduction in any medium, provided the original work is properly cited.

Nataliia Ostapiuk (Ukraine), Oleksandra Karmaza (Ukraine),
Mykola Kurylo (Ukraine), Gennady Timchenko (Ukraine)

ECONOMIC SECURITY IN INVESTMENT PROJECTS MANAGEMENT: CONVERGENCE OF ACCOUNTING MECHANISMS

Abstract

Implementation of business processes in Ukraine has become more structured in recent years. If previously the only goal was to get the most profitable investment and pay-off in the short term, and the attention to drawbacks and considerable riskiness of these projects was given already in case of their occurrence, now there is another management approach. Thus, the decision to attract additional funds involves a detailed analysis of the potential and existing risks of the project. The management focuses on continuous monitoring of the project implementation. Accordingly, it is necessary to develop an effective mechanism to evaluate an investment project, the effectiveness of its implementation, but from the perspective of the company's economic security aimed at identifying and diversifying risks.

As such, the accounting system of the enterprise's economic safety management is presented as to the investment projects execution based on the convergence of budgeting, management, financial accounting and elements of the economic analysis and control. The proposed system of investment project management is based on the definition of responsibility centers during the investment project implementation. The developed plan of actions and methods is aimed at creating effective tools for identifying risk factors and monitoring the investment projects effectiveness. Such a system provides an opportunity to operate an investment project promptly and flexibly, following clearly defined management tasks within the chosen strategy of enterprise's economic security.

System management of investment project, which is a part of the overall business management, contributes to the achievement of goals set by the company at a given level of risks and financial performance.

Keywords investment, risk, responsibility centers, budgeting, management accounting, economic security

JEL Classification G3, K2

INTRODUCTION

Company's economic security is formed by means of measures covering all its business processes. Moreover, such activities are determined by the proper preparation of necessary information, which makes it possible to establish the points of management influence and the nature of its intervention. Investment projects are one of the areas of focus. Variance in the investment project management involves a systematic approach to the tasks and methods of accounting for such management in integration with enterprise's economic security management as a whole.

Accounting for management, as one of the management elements, provides information necessary to monitor the current activities, strategic planning, efficient resource utilization, analysis and evaluation

of the overall enterprise's performance and its structural units, objective management decision making, information flows improvement, establishment of elements or activities that management can influence, and seek ways to assess risk sensitive factors.

Accounting figures are relevant only in case of low information asymmetry; therefore, it is rather difficult to provide standard performance measure for management accounting (Rapp, 2010).

Management accounting, while having access to both external and internal sources of information that changes influenced by catalytic efforts, as well as integrating its functions with the marketing, production, financial service, and management, ensures the reliability of an adequate information balancing that facilitates effective management, analysis, comparison and presentation of information, which can be used structurally for the control, evaluation and corrective functions of managing the business entity's economic security.

1. LITERATURE REVIEW

Stehnei, Irtysheva, Khaustova, and Boiko (2017) proposed a model of company's strategic control that takes into account both external and internal factors in creating an effective control system which considers Ukrainian companies' experience in the context of sustainable development.

In some cases, external factors cannot be predicted. This uncertainty may not only influence company's management accounting, but also investment strategy and economic security in implementing investment projects. Considering that, Kinias, Tsakalos, and Konstantopoulos (2017) suggested a model for the investment analysis in order to find an optimal investment strategy.

Kireitsev (1999) notes that "the system of management accounting is created based on validated methodological and organizational integration of control functions". According to Chumachenko (1997), modern management accounting includes rationing and forecasting the production costs in different directions, calculating the product cost, analysis of product cost, and detecting the deviations from standards and estimates". Skrypnyk (2011, p. 45) holds that the existing methods of accounting, valuation, planning, control and cost analysis can no longer meet the needs of agricultural enterprises' managers, and therefore it is necessary to create a system for processing and preparing information for managers within the enterprise, which can be solved with the use of management accounting. However, the distinction of management accounting in a separate information

system set new challenges for the academic community, professional organizations and experts to improve the quality of its product – an information resource for managerial decisions-making.

To deep interdisciplinary accounting relationships with other management functions, it is possible to bring its methodology closer to that of the enterprise's economic security management. According to Legenchuk (2012), implementing the transdisciplinary and interdisciplinary methodologies in accounting researches is one of the means to solve the problem of accounting identity crisis, it allows to identify the principles of the accounting system functioning, which should be the basis for its scientific theories.

2. THE STUDY PURPOSE

The study purpose is to disclose features of investment projects' information management in terms of enterprise's economic security and various management tools convergence: accounting subsystems' budgeting, analysis and control in order to ensure a timely and objective assessment of investment project's riskiness and efficiency.

3. RESULTS

Tasks the management accounting performs on the main stages of enterprise's economic security management are systematized in Table 1. The detailed analysis of these tasks will allow to systematically approach to the development of method-

ological accounting tools for the business entity' investment projects management.

After the problem is identified and the tasks to solve it are determined, the system of economic security management foreseen at the third stage is formed: definition of security objects and their analysis, establishing bodies for ensuring economic security, including the organizational structure of economic security management, development of mechanisms for its provision, basic criteria and indicators of such a security system.

Research synthesis and analysis of current approaches in management should be done for the economic security development. In hospitality management, Paiva, Reis, and Lourenço (2016) made a scientific review and proposed to categorize researches in hospitality management and accounting into three groups: studies of business management, financial management, and accounting. Creating categories of analytical information, approaches, and innovations can help to shape an integrated system of investment projects based on economic security, as it will take into account different areas of management accounting.

Horngrén and Foster (2001) prove that the company management develops the organizational structure and determines the divisions' responsi-

bility. Each manager is assigned to the responsibility center. The latter is a segment of an enterprise whose managers are accountable for a certain working area.

John A. Higgins has an interesting viewpoint as to the responsibility centers concept, namely: reporting is necessary for the purpose of efficient resource and standards utilization as a control over their activities and for spending money at any level of management. According to J. A. Higgins (1952), each structural unit is aggravated by only those expenses or incomes which it is responsible for.

The planning of responsibility centers operations irrespective of their type is carried out by drawing up flexible budgets, which are developed not for a certain amount, but for the certain range of production or sales of responsibility center, that is there are expected changes in the scope of activities. This allows to analyze the results of activities and identifying the causes of possible deviations.

Budgeting helps to identify and coordinate all factors of production by structural subdivisions and functional services in order to achieve the enterprise's goals. During the development of budgets, the enterprise's economic security is ensured due to the precise planning of the enterprise activity in accordance with the strategy of its development

Table 1. Stages of information support of the economic safety management system of an enterprise (in terms of management accounting)

| Stage | Stage name | Stage components | Tasks of management accounting |
|-----------------|--|---|---|
| 1 st | Problem description in respect of the enterprise's economic security | Analysis of enterprise's position, level of security, reports constituting confidential data and commercial secrets, reliability of human resources in preserving such information, as well as financial, intellectual, legal, information and other functional components of the enterprise's economic security. Potential and actual dangers and threats identification; their significance ranking in terms of occurrence time or size of possible damages. Identification of causal relationships, and danger and threat factors. Forecasting of possible dangers and threats' negative consequences, possible lost estimate. Formulating the problem situation | Presenting exact information on internal processes and operating results; providing this information to management by using internal management reporting |
| 2 nd | Determining the economic security purpose | Shaping the policy and strategy of enterprise's security. Setting the security objective. Setting tasks that contribute to achieving the goal and implementing the policy and strategy chosen | |
| 3 rd | Constructing the economic security system | Formulating the functions of the company's security system and choosing the principles for building this system. Defining security objects and analyzing their security status. Creation of bodies (subjects) for ensuring economic security, including organizational structure of enterprise's economic security management. Development of mechanisms for ensuring economic security, basic criteria and indicators for the state of such security | Planning and control for enterprise's performance and its responsibility centers |

Table 1 (cont.). Stages of information support of the economic safety management system of an enterprise (in terms of management accounting)

| Stage | Stage name | Stage components | Tasks of management accounting |
|-----------------|--|--|---|
| 4 th | Developing methodological tools to assess the state of economic security | Selecting the methods of risk analysis. Calculation of required resource amount, protection facilities for security objects | |
| 5 th | Development of measures to implement the basic provisions of the enterprise safety concept | Finding the sources of resource support for the concept implementation. Development of the strategic plan (or program), as well as the plans of the structural units of the security service to solve definite problems. Professional personnel training for the security service, as well as employees training on keeping safety rules, paperwork management, keeping commercial secrets, etc. Creating the certain type of security service and organizing its management, implementing the technical means of protection, etc. Development of enterprise security system, its continual adaptation to changing conditions; improving forms and methods of its performance. Determining the concept accordance, stated tasks and objectives of the created security system to real and potential threats and dangers | Cost accounting and product costs calculation. Calculating actual product cost (works and services) and determining the deviations from accepted standards and regulations, and budgets. Analysis of deviation from targets and identifying their causes. Drawing up the control accounts |
| 6 th | Summarizing the conclusions about the need to develop and implement the enterprise's economic security concept and its effective application | Security service's ability to address the challenges it faces. Level of resources adequacy for the concept implementation. Effectiveness of the enterprise's economic security implementation. Control over the effective implementation of economic security's basic provisions | Ensuring control over the movement of property, material, financial and labor resources. Building up a data base for decision making based on the management reporting analysis. Identifying resources for improving the enterprise's performance. Preventing negative results of the enterprise's business operations |

and the possibility of controlling the enterprise's economic risks.

Accounting for responsibility centers can be an effective means of managing costs and profits if there are validated choice of responsibility centers; reasonable costs estimates for centers contributing to cost reduction; adequate choice of controlled costs; reasonable choice of managers charged with expenses, incomes and profit; interconnection of responsibility centers reporting at different levels; accounting system at the responsibility centers in parallel with financial accounting.

Responsibility centers draw up reports using controllability concept, according to which there is no sense to load top-level management information, problems that can be solved at lower levels. Each responsibility center usually works on different programs. Manager's activities in each responsibility center must be evaluated according to his performance. The responsibility centers effectiveness can be assessed based on transfer pricing.

The key is the choice of methods both for risk analysis and for assessing the state of enterprise's eco-

nomical security. The calculation of the required resources and means for security objects protection involves determining the necessary amount of labor resources and the costs for their formation and maintenance, determining the financial costs necessary to ensure enterprise's safety. Then, necessary expenses with possible damage by hazards and threats, as well as further conditions that are sufficient to implement the concept are compared.

Development of measures to implement the main provisions of the enterprise's security concept based on information management system which is aimed at improving the enterprise economic security begins with finding sources of resource provision and ends with the enterprise's security system development, its constant adaptation to changing conditions, as well as its forms and methods improvement.

In order to achieve tasks stated at this stage, management accounting provides cost accounting and net cost calculation cost by various methods.

Influenced by the catalytic environment, there should be changes in priorities and approaches to

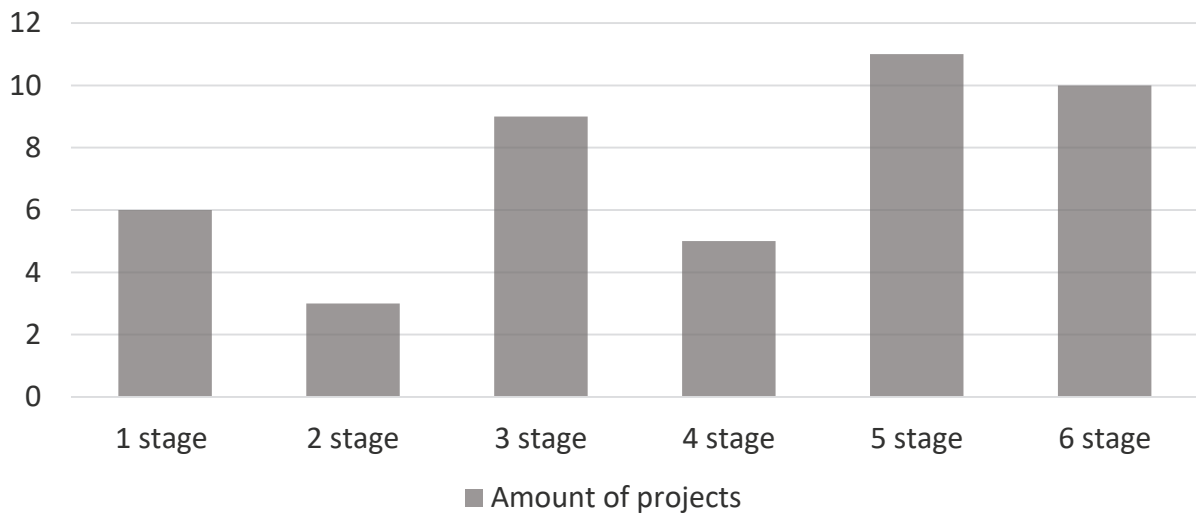

Figure 1. Investment projects by stages of development, pcs.

building the accounting system. They should take into account effects of both internal and external factors of business entities.

Taking into account the importance of information about investments for making management decisions, we propose to accumulate data on investment expenses in the account 86 “Cost of investment projects”, to which appropriate analytical sections should be organized. In this case, account 86 should not have a balance under normal operating conditions and is, in fact, a bill-screen.

An important consideration is the analysis of deviations from planned results and the deviations causes generated by a number of macro- and micro-environment factors, which give rise to various risks of the investment project.

In this case, both general and separate directions of entrepreneurial risks reduction, while implementing investment projects, should include: general directions – control over activities in related areas; risks transfer to counterparties; effective project team; risks insurance; reservation of funds; individual directions – involvement of professional designers, appraisers, marketers, etc., in the investment project development; studying the labor balance-sheet in the region; innovations control in the technological equipment market, etc.

Also, the risk from implementing an investment project depends on the stage of the project. For example, six stages of the investment project are highlighted on the Investment Portal of the Ukrainian Chamber of Commerce and Industry.

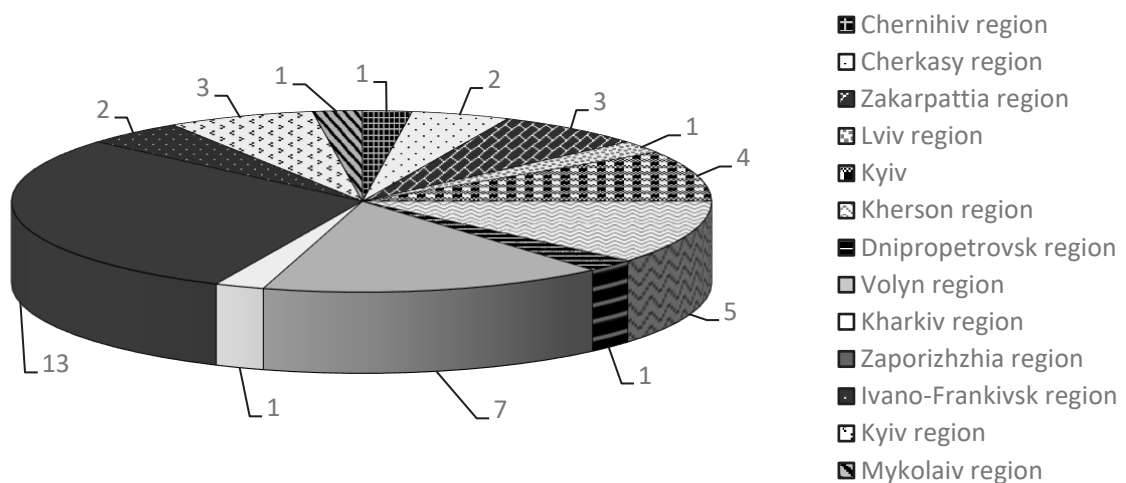

Figure 2. Investment projects in Ukraine by regions, pcs.

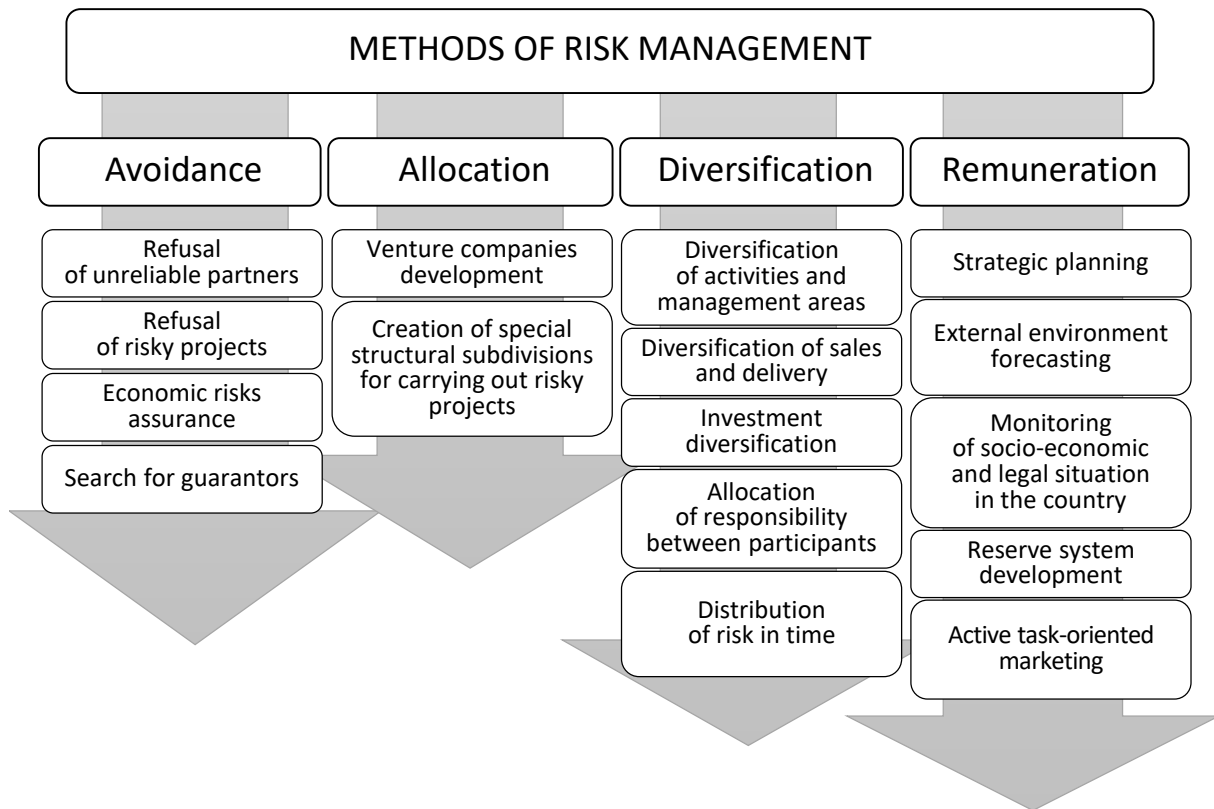

Figure 3. Methods of risk control for investment project implementation

While examining the basic information about the available subjects of investment (Figure 1), it can be observed that among development stages, the main number of projects falls on the 5th (the project is under implementation) and the 6th (the current project) stage, so then it is possible to estimate full value, profitability, and payback period investments in order to avoid external risk factors (political, economic). The smallest number is occupied by projects at the second stage – the level when only a business plan with a feasibility study is ready.

As to the regions of Ukraine (Figure 2), one may note that the largest number of investment projects is represented in Zaporizhzhia (13 projects) and Volyn (7 projects) regions. Such statistics is due to the fact that, for example, in Zaporizhzhia region, almost all projects are represented by Motor Sich enterprise, which manufactures engines for airplanes, helicopters, as well as industrial gas turbine installations, and that needs financing. Some areas are not represented at all for many reasons.

Risk assessment of projects by development stages is one of the simplest and most general assessment methods and can only serve as a supplement to

other evaluation methods or as a criterion for selecting possible projects.

Assessment of organizational risks at the present stage of economic development is proposed to be performed by using risk assessment forms through expert risk analysis and risk response measures. Measures to neutralize project risks and consequences involve avoiding, taking, transferring or mitigating the risks.

The management mechanism involves different methods (Figure 3).

Both highly profitable and less cost-effective projects can be the objects for next investments. This can be realized through diversification mechanisms. The latter is provided by an organizational and economic mechanism, which includes two subsystems. The economic subsystem reflects the enterprise's potential; organizational subsystem covers the purpose, organization, information support and criteria for goals achievement. The organizational and economic mechanism thus structured allows, to realize projects of activity diversification as an object of control and analysis. Increase

Table 2. Investment records form in the building up portfolio of proposals

| No. | Investment direction | Types of expenses according to investments | | | | | | | | | | | | Total | | | |
|-----|----------------------|--|--------|-----------|------------------------|--------|------------|----------------------------|--------|-----------|----------------------|--------|-----------|---------|--------|-----------|--|
| | | Consignment | | | Payment delay purchase | | | Acquisition at own expense | | | Acquisition of loans | | | Planned | Actual | Deviation | |
| | | Planned | Actual | Deviation | Planned | Actual | Deviation. | Planned | Actual | Deviation | Planned | Actual | Deviation | | | | |
| | | | | | | | | | | | | | | | | | |

in company's economic security effectiveness requires establishing the internal management reporting system. The latter includes information to managers, provided in a periodic and user-friendly manner. It should be noted that the specificity of each company consists in putting forward demands to the management reporting content.

In general, all the information reflected in the reporting can be divided into the following blocks: investments decisions and loans; cash receipt forecasting; analyzing sources of funding, need for new sources and revision of them; borrowed and own funds ratio; economic activity results and income; both short-term and long-term solvency, and cash flow; possible management actions; data interpretation and guidance for management.

It is expedient for the investment center to develop a structured form – investment records form in the building up a portfolio of proposals (Table 2), which will monitor the risks and take the necessary measures to prevent them.

Given that an active form of management allows to minimize the risk component of an investment project, it is suggested to formulate internal reporting – assessment of the investment center's activity form (includes indicators dynamics: sales revenue, UAN, average value of fixed assets, UAH, assets average, UAH), which allows to implement the above form of risk management, because active form of risk management means maximal use of information and management tools to minimize risks.

Constructed in this way, the concept of enterprise's economic security, taking into account the tasks assigned to the management accounting system (drawing up control reports; presenting unbiased information for making non-standard management decisions; forecasting and selecting the most effective ways for enterprise's development, overcoming the probability of profit loss, the identifying internal reserves, and ensuring enterprise's financial stability), promotes the effective managerial decisions by business managers in order to secure business.

CONCLUSION

Thus, company's economic security should cover all the enterprise's activities. If standard business processes are studied sufficiently by business entity when building the economic security system, then investment processes are still at the learning stage.

The investment processes, being very risky, require increased attention of managers. In particular, the project riskiness is to be assessed; from now, monitoring of the project implementation based on obtaining operational information and the final assessment of the project effectiveness should be detailed.

Convergence of economic mechanisms, namely: budgeting, management accounting (calculation methods, formation of transfer prices, management reporting), economic analysis and further control measures is proved to be the basis for the economic security management in the part of investment project.

In order to assess investment project effectiveness and determine its riskiness degree, the form of the management reporting is proposed, which allows quickly identifying the investment project challenges and taking measures to prevent violations in the enterprise's economic security functioning.

REFERENCES

1. Chumachenko, N. H. (1997). Развитие управленческого учета в Украине [Razvitie upravlencheskogo ucheta v Ukraine]. *Svit bukhhalterskoho obliku*, 10(16), 2-9.
2. Investment Portal, Ukrainian chamber of commerce and industry. Retrieved from <http://invest.ucci.org.ua/ua/proposal/project>
3. Khiggins, D. A. (1952). *Интеграция [Integratsiya]* (9th ed.). Chicago.
4. Khorngren, Ch. T. (2001). Бухгалтерский учет. *Управленческий аспект [Bukhhalterskiy uchets. Upravlencheskiy aspekt]*. Moscow: Finansy i statistika.
5. Kinias, I., Tsakalos, I., Konstantopoulos, N. (2017). Investment evaluation in renewable projects under uncertainty, using real options analysis: the case of wind power industry. *Investment Management and Financial Innovations*, 14(1), 96-103. [http://dx.doi.org/10.21511/imfi.14\(1\).2017.10](http://dx.doi.org/10.21511/imfi.14(1).2017.10)
6. Kireitsev, H. H. (1999). Про поділ обліку на фінансовий і управлінський [Pro podil obliku na finansoviy i upravlinskyi]. *Bukhhalteria v silskomu hospodarstvi*, 11, 2-7.
7. Lehenchuk, S. F. (2012). Бухгалтерське теоретичне знання: від теорії до метатеорії: монографія [Bukhhalterske teoretychne znannia: vid teorii do metateorii: monografiia] (336 p.). Zhytomyr: ZHDTU.
8. Paiva, I. S., Reis, P., Lourenzo, I. C. (2016). Research in hospitality management and accounting: a research synthesis and analysis of current literature and future challenges. *Problems and Perspectives in Management*, 14(4), 83-91. [http://dx.doi.org/10.21511/ppm.14\(4\).2016.10](http://dx.doi.org/10.21511/ppm.14(4).2016.10)
9. Rapp, M. S. (2010). Information asymmetries and the value-relevance of cash flow and accounting figures – empirical analysis and implications for managerial accounting. *Problems and Perspectives in Management*, 8(2), 64-75. Retrieved from https://businessperspectives.org/images/pdf/applications/publishing/templates/article/assets/3224/PPM_EN_2010_02_Rapp.pdf
10. Skrypnyk, H. O. (2011). Нормативно-правове регулювання управлінського обліку в сільськогосподарських підприємствах [Normatyvno-pravove rehuliuвання upravlinskoho obliku v silskohospodarskykh pidpriemstvakh]. *Oblik i finansy APK*, 1, 43-46.
11. Stehnei, M., Irtysheva, I., Khaustova, K., Boiko, Y. (2017). Modeling of strategic control system in the context of sustainable development of enterprise. *Problems and Perspectives in Management*, 15(3), 212-223. [http://dx.doi.org/10.21511/ppm.15\(3-1\).2017.05](http://dx.doi.org/10.21511/ppm.15(3-1).2017.05)