

“Combining resources and limiting the change boundary: the case of an ERP system implementation”

AUTHORS

Daniel Hjelmgren

ARTICLE INFO

Daniel Hjelmgren (2011). Combining resources and limiting the change boundary: the case of an ERP system implementation. *Innovative Marketing*, 7(2)

RELEASED ON

Thursday, 09 June 2011

JOURNAL

"Innovative Marketing "

FOUNDER

LLC “Consulting Publishing Company “Business Perspectives”



NUMBER OF REFERENCES

0



NUMBER OF FIGURES

0



NUMBER OF TABLES

0

© The author(s) 2026. This publication is an open access article.

Daniel Hjelmgren (Sweden)

Combining resources and limiting the change boundary: the case of an ERP system implementation

Abstract

This paper deals with combination and development of individual resource units that are embedded into networks of other units. The aim of the paper is to analyze the possibilities for a supplier and a buyer to limit the change boundary when adjusting their resources toward each other, and thus to predict the total outcome of a certain change. The paper is based on a case study on implementation of ERP (enterprise resource planning) systems. The case focuses on a Swedish ERP-supplier's development of a customer specific solution in interaction with one particular buyer, whose requirements could not be met by existing product features. The buyer is a subcontractor on the second tier in the automotive industry and implemented the ERP system in order to improve the coordination of certain sequentially dependent operations. The case reveals four different ways in which a supplier and a buyer may try to limit the change boundary, each of them associated with certain problems in predicting the total outcome of a specific change.

Keywords: resource combination, value, embeddedness, change boundary, case study, modularization.

Introduction

During the last decade, many academics have investigated resource combination across firm boundaries (cf. Wedin, 2001; Håkansson and Waluszewski, 2002; Gressetvold, 2004; Baraldi and Strömsten, 2009). According to Wedin (2001), new combinations often call for some adjustments of involved resources. Owing to the large number of interdependencies that always exists among resources, the effects of these adjustments may be widespread and difficult to foresee (Gressetvold, 2004). Consequently, it is difficult to predict the total outcome of a certain change.

The aim of this paper is to analyze the possibilities for a supplier and a buyer to limit the “*change boundary*” (Holmen, 2001) when adjusting their resources toward each other, and thus predict the total outcome of a certain change. Holmen defines the change boundary as the boundary within something is changed. According to her, changes include new and modified resources, as well as existing resources that are used in new combinations without being modified. In this paper the change boundary is drawn around new or modified resources, i.e., only changes that create development costs and/or might reduce the value of the resources in other combinations are considered.

According to Barney (1991), resources take various forms and involve broad categories of tangible and intangible assets including a firm's management skills, its organizational processes, as well as the routines and the information and knowledge controlled by the company. Some of these resources are influential through their financial impact, while others “may be critical to the organization even though it comprises only a small proportion of the total input” (Pfeffer and Salancik, 1978, p. 46).

A common perception is that the value of a specific resource is determined through its connections with other resources. This argument goes back to Penrose (1959) and her view of resources as being heterogeneous, implying that a resource has no predetermined value. The resource-based view (RBV) refers to resource heterogeneity for explaining firms' competitive position. Barney (1991), for example, argues that “with homogeneous resources, all firms can implement the same strategies; hence, no firm can differentiate itself from other firms, and nobody will have a competitive position” (Foss, 1997, p. 10). In this paper, an industrial network approach is used. Within the industrial network approach the heterogeneity assumption implies that value is created through exchanging and combining resources across firm boundaries (cf. Snehota, 1990; Håkansson and Snehota, 1995; Holmen, 2001). According to Snehota (1990), it is not the resource essentially, but rather the possible combinations with the resources of different counterparts that determine its value.

Within the industrial network approach it is further assumed that each resource unit is embedded in a network of interconnected resource units, where the change of one specific resource unit often calls for additional changes of some interconnected units (cf. Wedin, 2001; Håkansson and Waluszewski, 2002, Baraldi, 2003; Gressetvold, 2004; Håkansson and Harrison, 2006). Changes made when two resources are combined and adjusted towards each other may therefore affect the possibility to combine these two resources with other resources, as well as possible combinations of interconnected resources (Wedin, 2001). Hence, if it is difficult to limit the change boundary when combining and adjusting resources toward each other, it is also difficult to predict the total positive/negative outcome of a certain change.

A way for a supplier to deal with interconnectedness is to create modular products. The concept of modularization emerged in the 1960s. Simon (1962) showed that a product is a complex system, which is made up of many interacting parts. Each part is subordinated to the product system hierarchically. To simplify the complexity of the system, the product should be designed as a set of sub-assemblies (sub-systems) so that their assembly constitutes a new product (Simon, 1962).

Classic examples of modularization include the Sony Walkman, offered in 160 variations by “mixing and matching” modular components (Sanderson and Uzumeri, 1995), and IBM software designs created by modules of routines which can be combined to create customized programs (Cusumano, 1991). More recent empirical studies include home appliances (Worren et al., 2002), the automotive industry (Fredriksson, 2006) and the logistics services industry (Pekkarinen and Ulkuniemi, 2008).

The convenience of modularization has commonly been explained by the possibility to develop efficient customer specific solutions by only assembling standard components (cf. Ulrich, 1995; Sanchez and Mahoney, 1996). According to Sanchez and Mahoney (1996), it is facilitated by standardized interfaces, where each module is free, i.e., when changes can be made separately from other modules. However, for some modular products, such as enterprise resource planning (ERP) systems (cf. Harris, 2000), the supplier may not be able to create an efficient solution without having to add or redesign some additional components.

1. Research propositions and theoretical perspectives

Following the introduction two research propositions can be formulated.

Proposition 1. Since every resource unit is imbedded in a network of other resource units, it is difficult to limit the change boundary when combining and adjusting resources toward each other. In turn, this makes it difficult to predict the total positive/negative outcome of a certain change.

Proposition 2. Even for some modular products, such as ERP-systems, it can be difficult to limit the effects of a change and thus to predict the total positive/negative outcome of this change.

1.1. Resource combination. In order to facilitate studies of resource combination in industrial networks, Håkansson and Waluszewski (2002) divide resources into two categories: technical resource units and organizational resource units. While the first category is further divided into products (P) and production facilities (PF), the second category is further divided into business units (BU) and business relationships (BR).

Products (P) may be both single physical items and systems of items including additional services such as training and support. The features of a product (goods and/or services) are primarily developed when the supplier, by itself or in interaction with various buyers, tries to combine the product with certain other resources.

Production facilities (PF) include equipment, routines, and skills used in the production of products. The division between production facilities and products is a matter of perspective. A resource, which from a supplier’s point of view is perceived as a product, may be perceived as a facility from a buyer’s point of view. For example, when ABB (Asea Brown Boveri Ltd.) provides a robot to Volvo, ABB perceives this robot as a product produced in the company’s production facility. Volvo, on the other hand, perceives the same robot as a production facility used in the company’s production of automobiles. Just like products, production facilities may be developed when they are used in new resource combinations.

Business units (BU) organize both products and production facilities. A vital characteristic of business units is their memories with regard to how they organize products and production facilities due to earlier interaction. Just like products and production facilities, a business unit is not given once and for all. Every interaction may change business units’ knowledge with regard to how they organize products and production facilities, as well as their abilities to work with other business units.

Business relationships (BR) make it possible for business units to influence the utilisation and development of technical resource units that are controlled by other business units (cf. Araujo et al., 2003). Aside from giving access to other companies’ resources, and thereby being important resources in their selves, business relationships can be described as “*quasi-organizations*” (Blois, 1971; Richardson, 1972). This means that they can organize the exchange of products and connect different companies’ production facilities.

Interaction between the four different resource categories (products, production facilities, business units, and business relationships) may take place at: (1) the interface between two technical units; (2) the interface between a technical and an organizational unit; and (3) the interface between two organizational units. Two technical resource units interact (i.e., meet and have an effect on each other) when they are combined. In order for the units to fit with each other and as an integrated whole generate required services, new combinations usually call for some adaptations. Through the development/modification of certain technical features, these adaptations may contribute to the development of the involved units.

When organizational units combine technical resource units, and figure out how different technical resource units can be adapted towards each other, their knowledge about how to combine different resources changes through “*learning-by-doing*” (Arrow, 1962). This concurrent development of technical and organizational features (knowledge) is made at the interface between a technical and an organizational unit.

As mentioned above, combination of technical resource units is both performed within business units and business relationships. When it is performed within business relationships, learning also occurs in terms of “*learning-by-interaction*” (Lundvall, 1988) and/or “*learning-by-listening*” (Bångens, 1998). These two kinds of learning may change the organizational units’ knowledge about various technical resource units, including how to organize them. Both kinds of learning appear at the interface between two different organizational units.

Although the resources activated at a certain interface can appear to be nicely adapted to each other, they cannot be perfectly adapted to all the resources activated in related interfaces (Håkansson and Waluszewski, 2002). Hence, there will always be reasons to develop some of them in new directions. Furthermore, as soon as some interfaces are changed there will be effects on other interfaces (Gadde and Håkansson, 2001).

1.2. Resource embeddedness. Johanson and Wedin (2000) argue that, in order to create value, features of different resources in the network need to be taken care of. In other words, supplier and buyer need to consider the network of interdependent resource combinations in which individual resources are embedded. Contemporary embeddedness research starts with Granovetter’s classic article from 1985, where it is argued that organizations’ decision-making are very much affected by the networks of ongoing interpersonal relationships in which the organizations are embedded. In addition to this social dimension, there is also a technical dimension of embeddedness. Hughes (1987) points to the technical dimension of embeddedness by arguing that a technological system consists of different artefacts which interact and are adapted in order to function in the system. If an artefact is removed from the system or if its characteristics change, the other artefacts in the system may need to alter characteristics accordingly. According to Dhebar (1995), re-establishing the complementarities in a technical system which may have been disrupted by a certain change requires both time and money. Furthermore, as previously argued, the change of a technical resource unit may affect its value in other combinations.

According to Håkansson and Snehota (1989), no company is an island but rather embedded into a network of business relationships. Apart from a web of interactive relations between individuals (ibid.), every business relationship in this network may involve a large number of interfaces between technical resource units. Consequently, besides trying to limit the change within their own resource structures, both the supplier and the buyer may also try to limit possible negative effects on the resource structures of various third parties. Inspired by “the principle of non-proportional growth” (Boulding, 1953), Dubois, Hjelmgren and Håkansson (2002, p. 60) argue that there are “not necessarily decreasing impacts when getting further out from the focal relationships.” The principle of non-proportional growth says that: “when any structure grows, the proportions of its parts and of its significant variables cannot remain constant. That is to say, it is impossible to reproduce all the characteristics of a structure in a scale model of different size” (Boulding, 1953, p. 335). Therefore, “subsequent adjustments of a change are not necessarily proportional to the change itself” (Dubois et al., 2002, p. 60).

Hence, there are reasons to limit the extension of a change. Apart from reducing possible negative effects on the value of the supplier’s and the buyer’s own resources, preservation of established resource structures might reduce possible negative effects on the resources of various third parties.

2. Research design

The paper is based on a case study focusing on a Swedish ERP-system provider’s development of a customer specific solution in interaction with one particular buyer whose requirements could not be met by existing product features. The buyer is a subcontractor on the second tier in the automotive industry and implemented the ERP-system in order to improve the coordination of certain sequentially dependent operations. Case studies include a number of various applicable methodologies that complement one another (Yin, 2003). In this study, a combination of interviews (Kvale, 1996) and the studying of formal documents has been used.

A total of 45 interviews were performed with 36 different individuals, involving 6 firms. The interviews were conducted in the period of 1999 to 2004. On the supplier side, 11 system developers, 6 group managers, 3 product directions managers, and 2 application consultants were interviewed. On the buyer side, 7 production planners, 2 IT managers, 2 distribution managers, and 1 production manager were interviewed.

Although the length of the interviews varied, all people that were contacted agreed to participate without any hesitation. Each interview lasted anywhere from 30 minutes to three hours, but most had

an average length of about two hours. The formal documents used included information websites, brochures, annual reports, daily papers, magazines, and books about computer programming. Apart from confirming interview data, this secondary data contributed to improved understanding of the firm's different business contexts as well as enhanced knowledge about certain technical issues.

The case and the theoretical framework concurrently evolved through an "abductive" (cf. Alvesson and Skoldberg, 1994) research process where new empirical findings directed the search for theoretical concepts, and where the use of new theoretical concepts conversely directed the empirical field work. This way of confronting frameworks with empirical observations as the case study proceeds has been termed "systematic combining" (Dubois and Gadde, 2002).

For structuring and analyzing the data, the resource interaction model developed in Håkansson and Waluszewski (2002) was used (see Figure 1). This model was chosen because it has been proved to be suitable for investigating adaptations and interdependencies within resource networks (cf. Baraldi, 2003; Gressetvold, 2004; Håkansson and Harrison, 2006; Lind, 2006). As previously mentioned, the model divides resources into two categories: technical resource units and organizational resource units. While the first category is further divided into products (P) and production facilities (PF), the second category is further divided into business units (BU) and business relationships (BR).

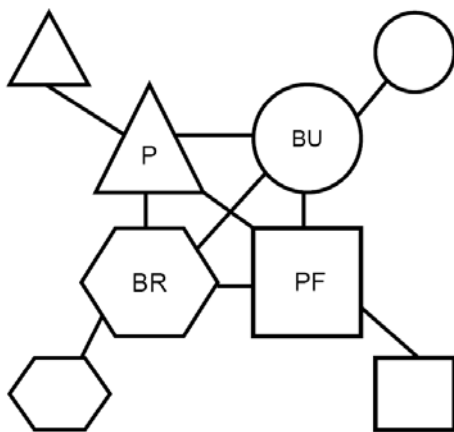

Fig. 1. Four different resource entities in a business network (Håkansson and Waluszewski, 2002).

3. The case of an ERP-system implementation

In 1998 Industrial Financial Systems (IFS) – a Swedish provider of ERP-systems – implemented a system at Borgstena Textile AB (BTAB). BTAB is a second tier supplier within the automotive industry and manufactures fabric mainly used in car seats. BTAB's production is divided between three different production plants. The first plant is a knitting works located in

Borgstena. This plant is divided into two different production lines: one for the circle knitted fabric and one for the warp knitted fabric. The most important input consists of yarn, colored yarn for the circle knitted fabric, and uncolored yarn for the warp knitted fabric. The second plant is a dye works located in Timmele. BTAB's planning situation in Timmele is regarded as the most complicated one, greatly due to its long sequence of different production steps. Just like in Borgstena, the production of automotive fabric is divided into two different production lines, one for the circle knitted fabric and one for the warp knitted fabric. In addition to these two, there is one line dedicated for the tricot industry. The third plant is a lamination works located in Getinge. This plant is entirely dedicated for the automotive industry. Apart from fabric from Timmele, important inputs in this production are foam rubber and backing. All three production plants have different production conditions in terms of efficient batch sizes, production speed, product varieties, setting times, and lead times.

As for many others of IFS' customers, BTAB's most important reason behind the implementation of an ERP-system was the company's wish to improve the coordination of certain sequentially interdependent operations. With an ERP-system it becomes easier for a company to coordinate various decision-making processes. The system not only stores data, but also determines the appropriate data to store, how to collect and group the data, and how to use the appropriate quantitative analyzes to process the data.

IFS's standard system is based on about 60 standard modules and divided into nine different "verticals". Each of these verticals consists of certain set of standardised modules, which has been made to fit with and contribute to the performance of certain segments of customers. The one which has been developed with supply and manufacturing chains in focus is called IFS automotive, and primarily aims to minimise lead times, administration costs, and capital tied up in inventory. Other verticals within IFS Application are "Process Industry", "Service Industries", "Telecommunications", "Engineering and Construction", "Defence", "Commercial Aviation", "Energy And Utilities", and "Hi-Tech". Apart from facilitating the marketing of the system, the division into different verticals improves the project department's ability to perform fast implementations. This is due to the modules being more suitable and more integrated.

Each module's functionality is divided between a "server" and a "client". The client includes instruction on how different kinds of data should be presented on the computer screen, and it is usually implemented on a personal computer running Windows NT. The basic building blocks are different standard

“forms”. Each form includes a certain number of “fields” where the data is presented or entered. The server, which may be further divided into a “database” and a “business logic”, is programmed in a software language called “PL/SQL”, except from the CBS Module, which due to its extra need of calculation capacity is programmed in C⁺⁺. A database consists of a large number of tables containing different categories of data, like descriptions of the business, operative data, and historical data. Since the database uses separate tables to store different types of data, there must be a way to connect data stored in one table with relevant data stored in other tables. In addition to tables, each module therefore contains “methods” for communicating with other modules. Every time a module needs information stored in another module, it calls for a certain “method” within this module to transfer the information.

At every new implementation IFS combines a set of modules into a customer specific solution. In order to make the solution fit with the buyer’s operations, most implementations call for some adaptations between the standard modules and the customer’s operations. Adaptations can be carried out in two different ways: (1) the customer adapts its operations to the functionality of the standard modules; or (2) IFS makes modifications of these modules that adapt the system solution to the buyer’s operations. The modifications are usually customer specific and separated from the standard system. However, IFS may also choose to integrate a modification into the standard system.

Integration of the functionality into the standard system improves IFS’s ability to spread development costs over a large number of different customer applications, and thereby gain through economies of scale. Since it often reduces the need of future customer specific adaptations, and thus the time spent on each implementation, it may also lower IFS’s implementation costs. However, it is not always an advantage to integrate a customer specific modification into the standard system. Although it may reduce the need of customer specific adaptations in some future implementations, it may increase this need during other implementations. Moreover, the integration of a customer specific modification into the standard system may call for additional adjustments during future upgrades of prior customer specific solutions. When IFS is particularly uncertain about the general need for a specific modification, the company always chooses to make it customer specific.

This paper takes its departure from the adaptations that were made by IFS and BTAB during the implementation project at BTAB. The project started with the establishment of a project team including members from both IFS and BTAB. Based on 14

different standard modules, this team developed BTAB’s customer specific solution. During the development IFS made some modifications in order to make the solution fit with BTAB’s production facilities. An important part of these modifications concerned three scheduling modules (the CS Module, the SS Module, the CBS Module). Conversely, BTAB adapted its existing facilities to the existing features of the ERP-system.

The CS (Customer Scheduling) Module receives orders and plans from customers. When the module receives a new order it always checks latest recorded delivery against the latest shipped quantities. The calculated difference is then deducted from the shipped quantities. In addition, the module also checks all received schedules against allowable tolerances. The SS (Supplier Scheduling) Module, which is designed as the mirror image of the CS Module, sends orders and plans to suppliers. The CBS (Constraint Based Scheduling) Module supports complex production situation by calculating the production times and the number of units which should be produced. When doing this, it both takes date of order and maximum capacity into consideration.

4. Development of individual resource units and the consequences on other units

In this section the development of individual resource units and the consequences on other units are analyzed. For this purpose, the previously presented model of Håkansson and Waluszewski (2002) is used. The analysis focuses on products and production facilities. While IFS’s ERP-modules are seen as products, BTAB’s ERP-system is seen as a production facility. Other important production facilities are BTAB’s three different production plants: (1) Borgstena; (2) Timmele; and (3) Getinge. Important facilities are also BTAB’s inspection and recipe systems.

During the implementation at BTAB, a certain set of IFS’s standard products (in terms of different modules) were combined into a specific production facility (in terms of BTAB’s ERP-system). In order to fit with, and contribute to the performance of BTAB’s existing production facilities (e.g., the production plant in Timmele), the new production facility (the ERP-system) was adapted to the features of these facilities. Conversely, BTAB adapted its existing facilities to the features of the ERP-system. IFS’s and BTAB’s adaptations resulted in some new product and facility features.

The analysis is divided into three sections. Section 4.1. deals with the standard product features which IFS developed in order to adapt the ERP-system to the features of BTAB’s three different production plants (Borgstena, Timmele, Getinge). An important

part of these adaptations concerned three scheduling modules (the CS Module, the SS Module, the CBS Module). Section 4.2. discusses three customer specific adaptations and how they resulted in different customer specific product features. Section 4.3. focuses on how BTAB adapted the features of its existing production facilities to the features of the ERP-system. This section also addresses how the implementation of the ERP-system affected two of BTAB's business relationships. Figure 2 shows how the development, due to investments made in features at certain functional and technical interfaces, embedded IFS's and BTAB's products and production facilities in each other.

In order to be able to illustrate what interfaces different features were developed and thus also the embeddedness, each product and production facility is given a certain number. This number includes two digits. The first digit indicates whether the resource unit is controlled by IFS or BTAB. While each resource unit controlled by IFS has a number that begins with 1 (e.g., P12 and P13), each resource unit controlled by BTAB has a numbers that begins with 2 (e.g., PF23 and PF24). The second digit (e.g., 2 in P12 or 3 in PF23) indicates the number of the resource unit.

Black lines are used for illustrating the interfaces at which new features were developed. Features are divided into product features and facility features. Facility features include new routines, new or modified production equipments, and new functionality of the ERP-system. Product features include new or modified "tables", "methods", and "forms" that, in combination, generate new ERP-system functionality.

4.1. Adaptations of three standard products.

BTAB's production facility is divided into three sequentially interdependent production plants: (1) Borgstena (PF22); (2) Timmele (PF23); and (3) Getinge (PF24). At the time of the implementation, their total production time always exceeded the lead time required by the customers. This called for some new features at the interface between BTAB's production plants and the ERP-system (PF21), enabling the system to deal with both orders and plans.

In order to generate these facility features, IFS developed some standard product features at the interface between the ERP-system and the standard version of the CS Module (P11). Apart from a new "table" for storing plan data, these features included "forms" for presenting this data. In addition, IFS also developed some new features of the Customer Order Module (P13). As previously mentioned, the Customer Order Module distributes orders to the MRP Module. In order to enable the Customer Or-

der Module to distribute plans, IFS needed to modify its features. Apart from a new "method" collecting plan data from the CS Module, IFS also developed a new "table" storing this data.

Besides its customers' requirements on short lead times, BTAB needed to deal with late order changes and unforeseeable errors. This called for some further features at the interface between BTAB's production plants (PF22, PF23, PF24) and the ERP-system (PF21), enabling the ERP-system to support decentralised production planning. In order to generate these facility features, IFS supplemented the CS Module (P11) with the SS Module (P12). Together they supported decentralised production planning by facilitating the division of BTAB's material resource planning into three steps. This, however, required that they were matched against each other. For example, every set of data sent from a particular "table" in the SS Module called for a similar "table" within the CS Module. Furthermore, since the SS Module in turn received these orders from the Purchasing Module (P14), IFS also needed to develop some additional features of the Purchasing Module. These features primarily concerned a "table" within the module storing plan data.

The utilizations problem at BTAB's production plant in Timmele (PF23) called for some new features of the CBS Module (P15). These features, enabling the CBS Module to consider setting times with respect to both colour tone and fixation temperature, were primarily developed in order to improve BTAB's utilization of the company's fixation and colouring equipments. Just like during the development of the CS Module and the SS Module, IFS economised on previously developed standard product features. These features primarily concerned a "method" collecting temperature data from a particular "table" within the Inventory Module (P17).

As previously mentioned, some of BTAB's customers require that BTAB gives the highest priority to their products. In addition to the "method" collecting temperature data from the Inventory Module (P17), IFS therefore developed a "method" within the CBS Module (P15) collecting priority data from a "table" within the Repetitive Production Module (P16).

4.2. Three customer specific adaptations. One of IFS's most important customer specific adaptations was to develop a connection between the ERP-system (PF21) and BTAB's inspection system (PF25), thus enabling a continuous use of the inspection system's user interface. This facility feature was primarily generated by a customer specific module (P18) including: (1) a "method" transferring data about the type and the length of a certain error

from the inspection system to two customer specific “tables”; and (2) an additional “method” transforming the data to the format normally used in IFS application. Apart from a customer specific “method” within the Repetitive Production Module (P16) collecting data about checked/refused quantities, this module was supplemented with a customer specific “column” within the Repetitive Production Module storing this data. Similarly, a customer specific “method” and a customer specific “column” collecting/storing data about stocked quantities were added to the Inventory Module (P17).

A second important customer specific adaptation was to develop a connection between the ERP-system (PF21) and BTAB’s recipe system (PF26), thus facilitating a continuous utilization of the recipe system’s calculation capacity. This facility feature was primarily generated by a customer specific module (P19) including: (1) a customer specific “method” transferring the recipe data to a certain customer specific “table”; and (2) an additional “method” transforming the data to the format normally used in IFS application. In addition to this module, IFS also developed a customer specific “method” within the Inventory Module (P17) transferring the transformed data to a customer specific “table” within this module. Furthermore, IFS developed a customer specific “method” in the Repetitive Production Module (P16) collecting recipe data from the Inventory Module every time BTAB runs the MRP Module.

A third customer specific adaptation was to develop a connection between the ERP-system (PF21) and ρ -Software’s EDI-converter (P31). This called for a minor modification of the EDI-converter which enabled the converter to read and write in the ERP-system.

4.3. Adaptations of BTAB’s production facility.

The implementation did not only result in adaptations of IFS’s products to the features of BTAB’s existing production facility, but conversely, the production facility was also adapted to the features of the ERP-system. Apart from new versions of BTAB’s recipe and inspection systems, BTAB changed its planning routines. Four different ways in which BTAB’s planning routines were changed can be identified. Firstly, the planning routines became standardized. By making the planners more interchangeable, this standardization improved BTAB’s ability to deal with sick-leaves. Secondly, each single operator along the production line became responsible for reporting production errors that appear during their respective production step. This improved BTAB error registration. Thirdly, the production output was now shipped

in accordance to carefully designed picking lists. This reduced the degree of shipment delays. Fourthly, the ERP-system made the production planners better informed about each others production. In addition, the automation of some planning activities gave them more time for personal interaction with each other. The knowledge that the planners gained about each others planning changed their ability to coordinate the production between BTAB’s different production plants. In other words, not only the plants’ (PF22, PF23, PF24) interfaces towards the ERP-system (PF21) were changed, but also their interfaces towards each other.

Owing to certain sequential interdependencies, the implementation of the ERP-system also affected two of BTAB’s business relationships. Firstly, it affected BTAB’s business relationship with π -Curtains (BR21), a supplier of curtains used in trucks. Although π -Curtains delivers directly to BTAB’s automotive customers, all communication with these customers are handled by BTAB’s production planners in Timmele. In order to be able to provide the automotive customers with information about the production status of different articles, and thus support their just-in-time production, BTAB needed to improve its access of information about π -Curtains’ production. For dealing with this situation, BTAB persuaded π -Curtains to implement the “client”, i.e. the part of the ERP-system making it possible to put-in and take-out data. This implementation changed the interface between π -Curtains production plant (PF41) and BTAB’s production facility. Secondly, the implementation of the ERP-system affected BTAB’s business relationship with σ -Lamination (BR22), a company which laminates fabric with backing and foam rubber. As σ -Lamination’s computerized business system was not compatible with ρ -Software’s EDI-converter, the company was not able to receive BTAB’s electronic messages. This triggered BTAB to send less fabric to σ -Lamination, and instead increase its utilization of Getinge’s production capacity.

Concluding from above, the existing features of BTAB’s production facility required development of certain features of the ERP-system. In order to generate these features, IFS had to adapt some parts of its product. These adaptations concerned both new standard product features and new customer specific product features. Conversely, BTAB adapted some parts of its production facility to the existing features of the standard products. At what interfaces the new product and facility features were developed is illustrated in Figure 2.

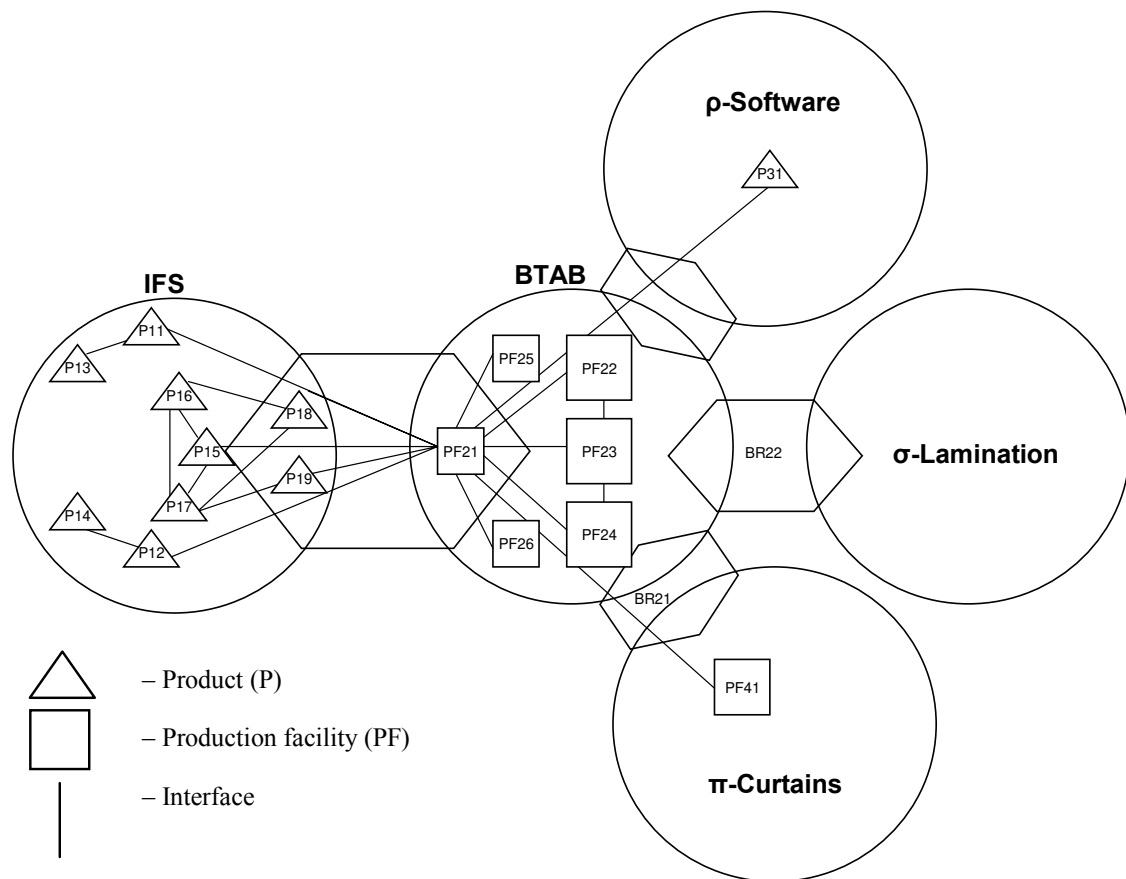

Fig. 2. Interfaces in which new features were developed.

As previously mentioned, every resource unit has been given a number including two digits. The first digit indicates who controls the resource unit. While, for example, each resource unit controlled by IFS has a number that begins with 1 (e.g., P12 and P13), each resource unit controlled by BTAB has a number that begins with 2 (e.g., PF23 and PF24). The second digit (e.g., 2 in P12 or 3 in PF23) indicates the specific number of the resource unit. Table 2 includes a list of the resource units at which interfaces new features were developed.

Table 2. Technical resource units at which interfaces new features were developed.

Number	Resource unit
PF21	BTAB's ERP-system
PF22	Borgstena
PF23	Timmele
PF24	Getinge
PF25	BTAB's inspection system
PF26	BTAB's recipe system
PF41	π-Curtains production plant
P11	Customer Scheduling Module
P12	Supplier Scheduling Module
P13	Customer Order Module
P14	Purchasing Module
P15	Constraint Based Scheduling Module
P16	Repetitive Production Module

P17	Inventory Module
P18	Customer specific module 1
P19	Customer specific module 2
P31	ρ-Software's EDI-converter
BR21	BTAB's business relationship with π -Curtains
BR22	BTAB's business relationship with σ-Lamination

5. Change boundaries in networks of technical resource units

Figure 2 illustrates that a change of one individual technical resource unit may call for additional changes of several other resource units. During the previously described resource interaction, these changes primarily concerned various technical resource units. Besides additional changes of some products (e.g., the Customer Order Module and the Purchasing Module), the case provides examples of additional changes of some production facilities (e.g., π-Curtains' information system). Indirectly, some business relationships were also changed. Apart from some additional changes of the business relationship with a supplier of curtains used in trucks, the changes of the buyer's production facilities called for additional changes of the business relationship with a company laminating fabric with backing and foam rubber. Even business units were changed. While the system supplier's business unit was changed as the company learned more about

how its products could be combined with certain other technical resource units, the buyer's business unit was changed as the company improved its ability to coordinate the production between different production facilities. Moreover, the business unit of the supplier of curtains were changed since it had to learn how to integrate a new production facility (i.e., the "client") into its established resource structure.

Some of these changes may be beneficial for the involved parties. For example, by changing the standard features of certain products, and the knowledge about how these products could be combined with other technical resource units, the system supplier could improve their value. Conversely, the buyer's changed planning routines, for example, reduced the degree of shipment delays between the companies different production sites. This improved the utilization of certain production facilities (e.g., the dye works), and consequently also the value of these technical resource units. However, additional changes may also result in larger development costs. Moreover, some additional changes of the system supplier's and the buyer's other resource units may make these units less suited for other combinations. As previously argued, companies' uncertainty regarding possible effects on other resource units, may make them try to limit the change boundary of their adaptations.

The case gives four examples of how the change boundary could be limited. A way to limit the change boundary in the buyer's established resource structure is to adapt the features of the supplier's products to the features of the buyer's resources. This may make the buyer suffer less from high switching costs, i.e., costs for re-establishing the complementarities that might be disrupted by the new product (Dhebar, 1995). Apart from the change of operational skills, that once internalized may be difficult to unlearn (David, 1985), and the acquirement of new products and production facilities compatible with the new product, these switching costs may include the development of new interfaces between the new product and its various complements. Moreover, adaptation of the supplier's products to the buyer's existing resource structure may reduce possible negative effects on the buyer's relationships with other counterparts. Finally, if the new features are integrated into the standard products, they may increase the value of these products in certain other combinations.

Unfortunately, adaptation of the supplier's products also has some important drawbacks. Firstly, it might reduce the value of the products in some other combinations. Secondly, it might call for extensive interaction between the buyer and the supplier, which penetrates deeply into the design process itself.

Apart from needing a capability to specify requirements, and thus some prior design knowledge, the buyer may have to make important investments in learning about the supplier's resource structure. Conversely, the supplier may have to invest a lot of time and capital in learning about the buyer's resource structure. Hence, adaptations of the supplier's products might both directly (due to time spent on learning, informing, persuading, negotiating, coordinating, and teaching) and indirectly (because of the higher price that the supplier may charge for the product) cause the buyer large interaction costs.

A way to avoid adaptation of the buyer's resources, and at the same time limit the change boundary within the supplier's established resource structure, is to, like the case company, develop customer specific product features separated from the standard product. This may reduce possible negative effects on the value of the product in other combinations and the cost of re-establishing disrupted complementarities within the resource structures of various third parties. Unfortunately, it might be difficult for the product supplier to reuse customer specific product features separated from the standard product in other customer applications. Hence, it may be little room for further exploitation on the developed features. From a buyer perspective, customer specific product features reduces the possibility to take advantage of the experiences that the supplier may gain from subsequent buyer interactions. Appleyard (2003) claims that, under certain conditions, the buyer should favour generally applicable modifications over customized modifications because they promote knowledge growth at the supplier over time. As the supplier's expertise grows, the company can improve its support of the equipment in the field, as well as convert the knowledge into equipment upgrades (Appleyard, 2003, p. 357).

Another way to limit the change boundary can be to apply a modular product architecture, where every standard product is divided into a certain number of modules with standardized interfaces. As a change made to one component does not necessarily require a change of other components in order for the product to work correctly as a whole (Henderson and Clark, 1990; Ulrich, 1995; Baldwin and Clark, 1997), a modular product may reduce the extent of customer specific product features, and consequently also the time and cost for developing customer specific solutions. However, the case illustrates that it can be difficult to isolate a change to one single module. Instead, the change of one module often called for additional changes of some other modules. Moreover, due to a modular product's larger scope of application (Harris, 2000), every change may affect a larger number of counterparts.

In order to provide modules that only require minor modifications when being used in new customer solutions, a supplier may, like the case company, gather its modules into different sets, each set being adapted to a segment of buyers with similar use contexts. A set of modules that are closer to the customer's needs at the beginning of the supplier-buyer interaction enables the supplier to provide a solution more quickly and at lower adaptation costs. Furthermore, the smaller scope of application may reduce the effects that a certain change may have on the resources of various third parties. Unfortunately, a smaller scope may also restrict the supplier's ability to support new customers that do not fit into any existing segment.

Conclusions

The case confirmed the proposition that it is difficult to limit the change boundary when combining and adjusting resources towards each other. Besides a large number of additional changes of technical resource units (products and production facilities), the case provide several examples of additional changes of organizational resource units (business relationships and business units). It was argued that even though the change of a specific resource unit may increase the unit's value in some combinations, it may also reduce its value in other combinations. The case showed that owing to the interconnectedness between different resource units the total effects of a certain change may be widespread and difficult to foresee. Hence, when companies do not manage to limit the change boundary, it becomes difficult for them to predict the total positive/negative outcome of a certain change.

The case revealed four ways in which companies may try to limit the change boundary, each of them associated with certain problems in predicting the total positive/negative outcome of a specific change. A way to limit the change boundary in the buyer's part of the resource network is to adapt the supplier's products to the features of the buyer's existing resource structure. Adaptation of the supplier's products may reduce the buyer's costs for re-establishing complementarities which might be disrupted by the new product. It may also reduce possible negative effects on the buyer's relationships with other counterparts. Furthermore, adaptations that are integrated into the standard product may increase the value of this product in certain other combinations. Unfortunately, adaptation of the supplier's products may also reduce the value of the product in some other combinations. Moreover, it may directly and indirectly (because of the higher price that the supplier may charge for the product) increase the buyer's interaction costs.

The case showed on three ways to limit the change boundary in the supplier's part of the resource network. Firstly, the supplier may provide additional product features separated from the standard products. By not changing its standard products a supplier can reduce possible negative effects on the value of the standard product in other combinations and the cost of re-establishing disrupted complementarities within the resource structures of various third parties. However, additional product features separated from the standard product might also reduce the room for further exploitation on the developed features. It may also impede the knowledge growth at the supplier over time.

Secondly, the supplier may create a modular product architecture, where every standard product is divided into a certain number of modules with standardized interfaces. Since a change made to one component does not necessarily require additional changes of other components for the product to work correctly as a whole, a modular product architecture may reduce the total need of customer specific product features. However, as been shown in this paper, it is not an easy task to isolate a change to only one module. Furthermore, due to a modular product's larger scope of application, every change may affect a larger number of different counterparts. Hence, the case also confirmed the proposition that even for some modular products, such as ERP-systems, it is difficult to limit the effects of a change, and thus predict the total positive/negative outcome of this change.

In order to provide modules that only require minor modifications when being used in new customer solutions, the case company gathered its modules into different sets of modules, each set being adapted to a certain segment of customers. This may also reduce the negative effects that a certain change may have on various third parties. Unfortunately, modules which are more adapted to specific customers resource structures may also restrict the supplier's ability to support new customers that do not fit into any existing segment.

This paper primarily concerned the difficulties in limiting the change boundary within the supplier's resource structure. Future research should focus more on difficulties in limiting the change boundary within the buyer's resource structure. Can a buyer's production facility be divided into a certain number of modules with standardized interfaces, or are there other ways to limit the change boundary within a buyer's resource structure? What are their different advantages and disadvantages? To answer these questions we need more information about buyers.

References

1. Alchian, A.A. and Demsetz, H. (1972). Production, Information Costs, and Economic Organization, *The American Economic Review*, 62, pp. 777-795.
2. Alvesson, M., Sköldbberg, K. (1994). *Tolkning och reflektion – Vetenskapsfilosofi och kvalitativ metod*. Lund: Studentlitteratur.
3. Araujo, L., Dubois, A., and Gadde L.E. (2003). The Multiple Boundaries of the Firm, *Journal of Management Studies*, 40 (5), pp. 1256-1277.
4. Arrow, K. (1962). The economic implications of learning by doing, *Rev Econ Stud.*, 29, pp. 15-73.
5. Baldwin, C.Y. and Clark, K.B. (1997). Managing in an age of modularity, *Harvard Business Review*, pp. 84-93.
6. Baraldi, E. (2003). *When Information Technology Faces Resource Interaction – Using IT Tools to Handle Products at IKEA and Edsbyn*, Ph.D. thesis, Department of Business Studies, Uppsala University, Uppsala.
7. Baraldi, E. and Strömsten, T. (2009). Controlling and combining resources in networks – from Uppsala to Stanford, and back again: the case of biotech innovation, *Journal of Industrial Marketing Management*, 28, pp. 541-552.
8. Barney, J. (1991). Firm resources and sustained competitive advantage, *Journal of Management*, 17, pp. 99-120.
9. Blois, K. (1971). Vertical Quasi-Integration, *Journal of industrial Economics*, 20 (3), pp. 253-272.
10. Boulding, K. (1953). Toward a General Theory of Growth, *The Canadian Journal of Economics and Political Science*, 19, pp. 326-40.
11. Bångens, L. (1998). *Inter-Firm Linkages and Learning – an Empirical Exploration of Firms in the Third World*, Ph.D. thesis, Department of Industrial Marketing, Chalmers University of Technology, Gothenburg.
12. Cusamano, M.A. (1991). *Japan's Software Factories: a Challenge to U.S. Management*, Oxford University Press, New York.
13. David, P.A. (1985). Clio and the Economics of QWERTY, *American Economic Review*, 75 (2), pp. 332-337.
14. Dhebar, A. (1995). Complementarity, Compatibility, and Product Change: Breaking with the Past?, *Journal of Product Innovation Management*, 12, pp. 136-152.
15. Dubois, A. and Gadde, L.E. (2002). Systematic combining: an abductive approach to case research, *Journal of Business Research*, 55, pp. 553-560.
16. Dubois, A., Håkansson, H. and Hjelmgren, D. (2002). Technological Development in Networks: The Importance of Third Parties, *Sinergie*, 58, pp. 45-64.
17. Foss, N. (1997). *Resources, Firms, and Strategies – a Reader in the Resource-Based Perspective*, Oxford: Oxford University Press.
18. Fredriksson, P. (2006). Mechanism and rationales for the coordination of a modular assembly system. The case of Volvo Cars, *International Journal of Operations and Production Management*, 26, 4, pp. 350-70.
19. Gadde, L.E. and Håkansson, H. (2001). *Supply Network Strategies*, Chichester: John Wiley and Sons.
20. Grant, R. (1991). The resource based theory of competitive advantage: implications for strategy formulation, *California Management Review*, 33 (3), pp. 114-135.
21. Gressetvold, E. (2004). *Product Development – Effects on a Company's Network of Relationships*, Ph.D. thesis, Department of Industrial Economics and Technology Management, Norwegian University of Science and Technology, Trondheim.
22. Harris R. (2000). "Customization versus Standardization: Striking a Balance in ERP Software," *Machine Design*, 72, 14, pp. 64-69.
23. Harrison, D. and Håkansson, H. (2006). Activation in resource networks: a comparative study of ports, *Journal of Business and Industrial marketing*, 21, pp. 231-238.
24. Henderson R.M. and Clark K.B. (1990). Architectural Innovation: the Reconfiguration of Existing Product Technologies and the Failure of Established Firms, *Administrative Science Quarterly*, 35, pp. 9-30.
25. Holmen, E. (2001). *Notes on a Conceptualization on Resource-Related Embeddedness of Inter-Organizational Product Development*, Ph.D. thesis, University of Southern Denmark, Sønderborg.
26. Hughes, T. (1987). The Evolution of Large Technological Systems", In Bijker, Hughes, and Pinch. (Eds.), *The Social Construction of Technological Systems*, Cambridge: MIT Press.
27. Håkansson, H. and Snehota, I. (1989). No Business is an Island, *Scandinavian Journal of Management*, 5 (3), pp. 187-200.
28. Håkansson, H. and Waluzewski, A. (2002). *Managing Technological Development*, London: Routledge.
29. Kvale, S. (1997). *Den kvalitativa forskningsintervjun*, Lund: Studentlitteratur.
30. Langlois R.N. (1999). Scale, Scope and the Reuse of Knowledge. Paper for the conference in honor of Brian J. Loasby, Scotland: Stirling.
31. Lind, F. (2006). *Resource Combining across Inter-Organisational Project Boundaries*, Ph.D. thesis, Department of Technology Management and Economics, Chalmers university of Technology, Göteborg.
32. Lundvall, B.Å. (1988). Innovation as an interactive process: from user-producer interaction to the national system of innovation, in Dosi, G., Freeman, C., Nelson, R., Silverberg, G. and Soete, L. (Eds.), *Technical Change and Economic Theory*, London: Pinter Publishers.

33. Penrose, E. (1959). *The Theory of the Growth of the Firm*, Oxford: Basil Blackwell.
34. Pfeffer, J., Salancik, G. (1978). *The External Control of Organizations: a Resource Dependence Perspective*, New York: Harper and Row.
35. Ulrich, K. (1995). The role of product architecture in the manufacturing firm, *Research Policy*, 24, pp. 419-440.
36. Richardson, G.B. (1972). The organization of Industry, *The Economic Journal*, September, pp. 883-896
37. Pekkarinen, S. and Ulkuniemi, P. (2008). Modularity in developing business services by platform approach, *International Journal of Logistics Management*, 19, 1, pp. 84-103.
38. Sanchez, R. and Mahoney, J.T. (1996). Modularity, flexibility, and knowledge management in product and organization design, *Strategic Management Journal*, 17, Winter Special Issue, pp. 63-76.
39. Sanderson, S. and Uzumeri, M. (1995). Managing product families: the case of the Sony Walkman, *Research Policy*, 24, pp. 761-782.
40. Snehota, I. (1990). *Notes on a Theory of the Business Enterprise*, Ph.D. thesis, Uppsala University, Uppsala.
41. Simon, H.A. (1962). The Architecture of Complexity, *Proceedings of the American Philosophical Society*, 106, pp. 467-482.
42. Wedin, T. (2001). *Networks and Demand. The use of Electricity in an Industrial Process*, Ph.D. thesis, Uppsala University, Uppsala.
43. Wernerfelt, B. (1984). A resource based view of the firm, *Strategic Management Journal*, 5, pp. 272-280.
44. Worren, N., Moore, K., Cardona, P. (2002). Modularity, strategic flexibility, and firm performance: a study of the home appliance industry, *Strategic Management Journal*, 23, pp. 1123-1140.
45. Yin, R.K. (2003). *Case Study Research: Design and Methods*, London: SAGE (Third edition).