

“Formulization of MRCGE-GTAP for GHG discharge reduction policy evaluation-simulation of Global Emissions Trading Scheme”

AUTHORS

Yasuhisa Hayashiyama
Masahiro Abe

ARTICLE INFO

Yasuhisa Hayashiyama and Masahiro Abe (2011). Formulization of MRCGE-GTAP for GHG discharge reduction policy evaluation-simulation of Global Emissions Trading Scheme. *Environmental Economics*, 2(4)

RELEASED ON

Tuesday, 03 April 2012

JOURNAL

"Environmental Economics"

FOUNDER

LLC “Consulting Publishing Company “Business Perspectives”



NUMBER OF REFERENCES

0



NUMBER OF FIGURES

0



NUMBER OF TABLES

0

© The author(s) 2026. This publication is an open access article.

Yasuhisa Hayashiyama (Japan), Masahiro Abe (Japan)

Formulization of MRCGE-GTAP for GHG discharge reduction policy evaluation – simulation of Global Emissions Trading Scheme

Abstract

This report describes the development of a Multi-Regional Computable General Equilibrium model (MRCGE) that can express the incidence of benefits and costs by region and by industry to evaluate Japan's Greenhouse Gas (GHG) reduction policy. Furthermore, the paper attempts to extend this MRCGE to a model that is interlocked with GTAP-E and thereby elucidate changes in the world economic structure. The authors designate this developed model as MRCGE-GTAP. This study examines this policy from a viewpoint of cost efficiency with the intention of contributing to evaluation of international GHG discharge reduction policy. First, the authors assess the Kyoto-type framework that sets emission targets for developed countries and which has no targets for developing countries from economic and environmental perspectives using MRCGE-GTAP. The authors consider a Global Emissions Trading Scheme (GETS) as an alternative to the Kyoto Protocol and assess GETS from economic and environmental perspectives.

Keywords: multi-regional CGE, GTAP, GHG reduction policy, global emissions trading scheme.

JEL Classification: Q51, Q54, Q58.

Introduction

In a speech given at the United Nations Summit on Climate Change on September 22, 2009, Prime Minister of Japan, Yukio Hatoyama, pledged that "Japan will reduce its Greenhouse Gas (GHG) emissions by 25% by 2020 from 1990 levels". He clarified that Japan's commitment to its ambitious targets is premised on agreement by other major economies. Still, his pledge of the 25% GHG emissions cut and assistance to developing countries might catalyze a movement to negotiations for establishing a global framework for efforts against global warming from 2013 after the Kyoto Protocol expires in 2012. To achieve this, Japan must first make strenuous efforts to meet its obligations under the Kyoto Protocol.

However, when implementing policies to meet those goals, after assuming various policy alternatives, it is necessary to determine the best mix of policies by comparison of the *deadweight loss* that each policy might entail. For that reason alone, it is indispensable to elucidate the effects of policies by region and industry. The world's nations are evaluating GHG reduction policies given that background using the Computable General Equilibrium model (CGE), which expresses a circular flow of an economic system. This report describes development of a Multi-Regional Computable General Equilibrium model (MRCGE) that can express the incidence of benefits and costs by region and industry. Using it, the GHG reduction policy of Japan can be evaluated appropriately. Also, the interregional Input-Output Table (I/O) created originally with this study for use with MRCGE can clarify and assess effects of GHG reduction policies. Moreover, the possibility that domestic capital will flow

abroad can be assessed by evaluating the effects of GHG reduction policies in Japan. This study, therefore, produces an interlocking *energy-environment version* of GTAP (GTAP-E) and MRCGE, and extends it to assess changes of the global economic structure according to a conformable model. We designate this developed model as MRCGE-GTAP. Burniaux and Truong (2001) introduced the GTAP-E model, which was specialized for environment policy analysis using the Global Trade Analysis Project Model (GTAP) by Hertel and Tsigas (1997) of Purdue University as a basis for its development. Later, Ianchovichina and McDougall (2000), Rutherford and Paltsev (2000), and Fischer and Fox (2007) improved GTAP to the dynamic model.

This study examines this policy from the viewpoint of cost efficiency, with the intention of contributing to evaluation of international GHG discharge reduction policy. In this study, the performance of MRCGE-GTAP is verified using a Global Emissions Trading Scheme (GETS) foundation with case studies.

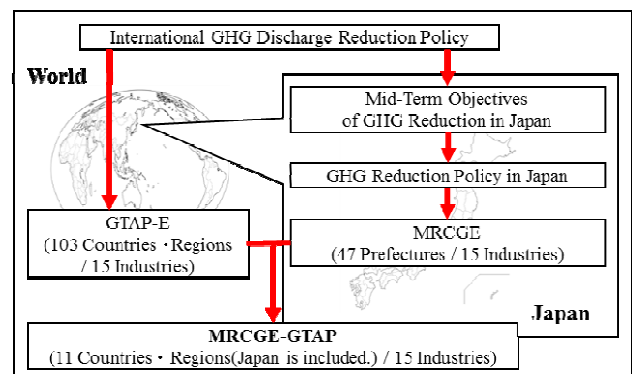

Fig. 1. Concept of this study

1. MRCGE structure and simultaneous equations system

The MRCGE model used for this study is a multi-regional static CGE model incorporating the assump-

tion of a perfectly competitive market and zero profit. International trade follows a small country assumption and the Armington's (1969) assumption. This model was based on the one-country static CGE model proposed by Hosoe et al. (2010), but details related to the model structure are explained by Hayashiyama et al. (2012). The structure and its simultaneous equations system of MRCGE (47 prefectures and 15 industry classifications) produced by this research are shown in order of (1) domestic production section, (2) household consumption section, (3) government section, (4) export and domestic modification/import and domestic sub-stitution, and (5) market equilibrium conditions.

1.1. Domestic production section. The domestic production section has a nested structure like that shown in Figure 2. In the following, optimization problems (P.1)-(P.3) of domestic production section describe all production activities that include all constant elasticity of substitution (CES-type) production functions presented in Figure 2. Elasticity of substitution and other aspects of MRCGE are based on descriptions presented in Ban (2007). The elasticity of substitution parameters are shown in Appendix, Table 2A. Moreover, intermediate input goods XX_{ij}^{rs} under profit maximization behavior assume, that composite intermediate input goods X_{ij}^s shall be produced. To produce production good Z_j^s , investment of composite production factors Y_j^s and X_{ij}^s is necessary. The Leontief-type production function has a constant input coefficient, as in many studies. However, many studies of this field, such as that of Ban (2007), have been undertaken to capture change in the production structure using a CES-type production function. Furthermore, details of the notation of subscripts, variables, and the simultaneous equations system are available in Appendix, Section 1, Table 1A.

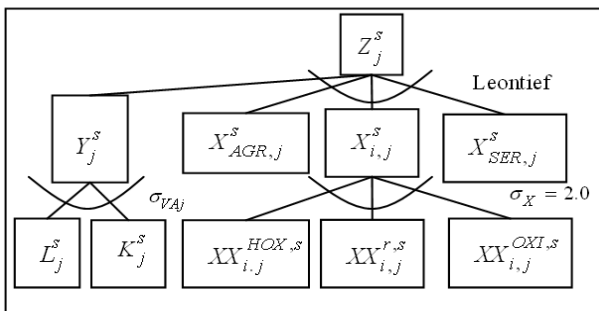

Fig. 2. Structure of domestic production section

$$\begin{cases} \max_{L_j^s, K_j^s} P_{Y_j^s} Y_j^s - P_{L_j^s} L_j^s - P_{K_j^s} K_j^s \\ \text{s.t. } Y_j^s = \alpha_{LK_j^s} \left[\beta_{L_j^s} L_j^{\frac{\sigma_{VA_j}-1}{\sigma_{VA_j}}} + \beta_{K_j^s} K_j^{\frac{\sigma_{VA_j}-1}{\sigma_{VA_j}}} \right]^{\frac{\sigma_{VA_j}}{\sigma_{VA_j}-1}}, \end{cases} \quad (P.1)$$

$$\begin{cases} \max_{XX_{ij}^{rs}} P_{X_{ij}^s} X_{ij}^s - \sum_{r \in R} P_{Q_i^r} XX_{ij}^{rs} \\ \text{s.t. } X_{ij}^s = \alpha_{XX_{ij}^{rs}} \left[\sum_{r \in R} \beta_{XX_{ij}^{rs}} XX_{ij}^{rs} \right]^{\frac{\sigma_X-1}{\sigma_X}}, \end{cases} \quad (P.2)$$

$$\begin{cases} \max_{Y_j^s, X_{ij}^s} P_{Z_j^s} Z_j^s - P_{Y_j^s} Y_j^s - \sum_i P_{X_{ij}^s} X_{ij}^s \\ \text{s.t. } Z_j^s = \min \left[\frac{Y_j^s}{\alpha_{Y_j^s}}, \frac{X_{AGR,j}^s}{\alpha_{X_{AGR,j}^s}}, \dots, \frac{X_{SER,j}^s}{\alpha_{X_{SER,j}^s}} \right]. \end{cases} \quad (P.3)$$

1.2. Household consumption section. The structure of the household consumption section is portrayed in Figure 3. Households are based on utility-maximization behavior; utility level UH^s is acquired by consuming XH_i^s . Moreover, because the elasticity of substitution of utility function is $\sigma_H = 0.5$, it serves as a Cobb-Douglastype utility function. Therefore, utility maximization behavior of the households can be formulized as in (P.4).

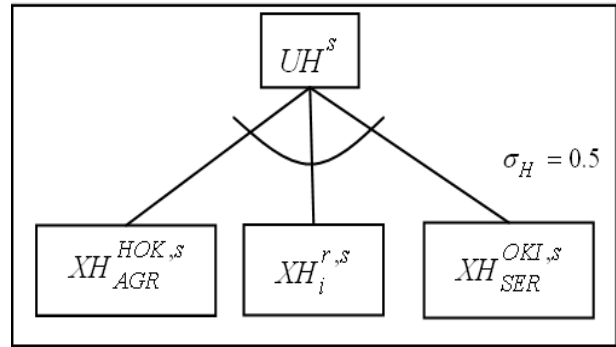

Fig. 3. Structure of household consumption section

$$\begin{cases} \max_{XH_i^{rs}} UH^s = \left[\sum_{r \in R} \sum_{i \in I} \beta_{XH_i^{rs}} \frac{1}{\sigma_H} XH_i^{rs} \right]^{\frac{\sigma_H-1}{\sigma_H}} \\ \text{s.t. } P_{L^s} F_{L^s} + P_{K^s} F_{K^s} - TD^s - HS^s = \sum_{r \in R} \sum_{i \in I} P_{Q_i^r} XH_i^{rs} \end{cases} \quad (P.4)$$

The equivalent variation of welfare economics defines the utility level and social public welfare in this study.

1.3. Government section. The respective structures of government expenditure and investment are presented in Figure 4 and Figure 5. It portrays government expenditure and the investment section. As the structure shows, the government's income is based on taxation of three kinds: a production tax, adirect tax, and tariff payments. Direct taxes include labor income tax and capital tax. The government collects these taxes as government income and spends them on consumption and investment. Therefore, utility UG^s and UI^s maximization behavior of government can be formulized as (P.5) and (P.6).

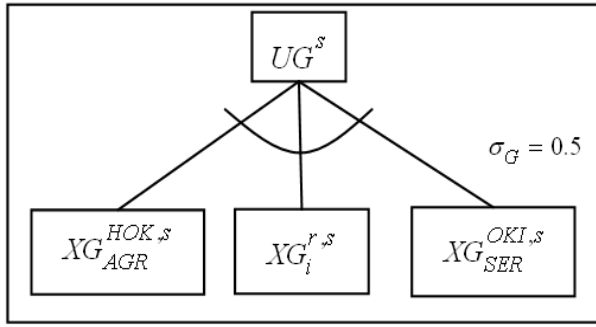

Fig. 4. Structure of government expenditure

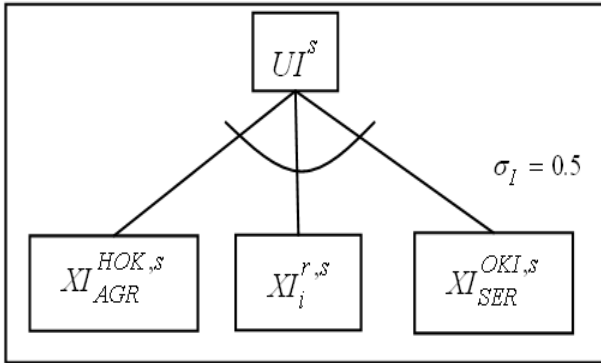

Fig. 5. Structure of government investment

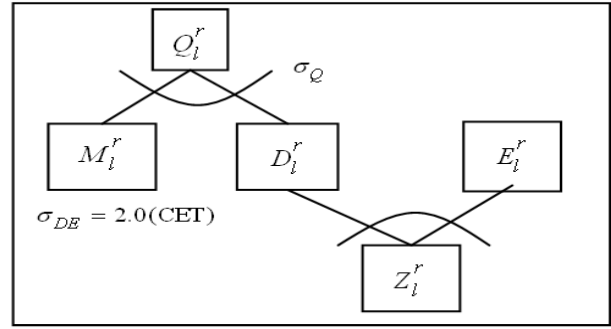

Fig. 6. Structure of exports and imports

$$\begin{aligned} \max_{XG_i^{rs}} UG^s &= \left[\sum_{r \in R} \sum_{i \in I} \beta_{XG_i^{rs}} \frac{1}{\sigma_G} XG_i^{rs} \frac{\sigma_G - 1}{\sigma_G} \right]^{\frac{\sigma_G}{\sigma_G - 1}}, \quad (P.5) \\ \text{s.t. } \sum_{j \in J} TZ_j^s + TD^s + \sum_{j \in J} TM_j^s - GS^s &= \sum_{r \in R} \sum_{i \in I} P_{Q_i^r} XG_i^{rs} \end{aligned}$$

$$\begin{aligned} \max_{XI_i^{rs}} UI^s &= \left[\sum_{r \in R} \sum_{i \in I} \beta_{XI_i^{rs}} \frac{1}{\sigma_I} XI_i^{rs} \frac{\sigma_I - 1}{\sigma_I} \right]^{\frac{\sigma_I}{\sigma_I - 1}}, \quad (P.6) \\ \text{s.t. } HS^s + GS^s + \varepsilon SF^s + TR^s &= \sum_{r \in R} \sum_{i \in I} P_{Q_i^r} XI_i^{rs} \end{aligned}$$

1.4. Export and domestic modification / import and domestic substitution. In this MRCGE, as portrayed in Figure 6, virtual private firms are transformed into domestic supply D_i^r and export E_i^r according to the Armington assumption. In the export structure, the local total output is divided into export supply and domestic supply. This division procedure is based on a Constant Elasticity of Transformation (CET) function. In addition, Figure 6 presents the import structure of the model. It might be said that the imported goods from the world market are combined with the local supply in a CES-type function under the Armington assumption. Those composite commodities are used to satisfy different demands such as production input or household consumption for the local region. Therefore, the structure of export and domestic modification, import and domestic substitution can be formulized as in (P.7) and (P.8).

$$\begin{aligned} \max_{D_i^r, E_i^r} P_{D_i^r} D_i^r + P_{E_i^r} E_i^r - (1 + \tau_{Z_i^r}) P_{Z_i^r} Z_i^r \\ \text{s.t. } Z_i^r = \alpha_{DE_i^r} \left[\beta_{D_i^r} D_i^r \frac{\sigma_{DE} + 1}{\sigma_{DE}} + \beta_{E_i^r} E_i^r \frac{\sigma_{DE} + 1}{\sigma_{DE}} \right]^{\frac{\sigma_{DE}}{\sigma_{DE} + 1}}, \quad (P.7) \end{aligned}$$

$$\begin{aligned} \max_{D_i^r, M_i^r} P_{Q_i^r} Q_i^r - P_{D_i^r} D_i^r - (1 + \tau_{M_i^r}) P_{M_i^r} M_i^r \\ \text{s.t. } Q_i^r = \alpha_{DM_i^r} \left[\beta_{D_i^r} D_i^r \frac{\sigma_{Q_i} - 1}{\sigma_{Q_i}} + \beta_{M_i^r} M_i^r \frac{\sigma_{Q_i} - 1}{\sigma_{Q_i}} \right]^{\frac{\sigma_{Q_i}}{\sigma_{Q_i} - 1}}, \quad (P.8) \end{aligned}$$

1.4. Market equilibrium conditions. The market equilibrium conditions of MRCGE are represented as four equations. These three equations respectively represent the commodity market equilibrium condition, and the balance of the capital market and labor market. In the capital market, MRCGE is based on the assumption that all capital in a country can be transferred freely among regions and industries, rendering it a perfect open model of capital. Therefore, the capital price is calculated as uniform ($r^s = r$). The last condition is fixed to zero as the sum total of income transfer. For that reason, $\sum_{s \in S} TR^s$ is useful as numéraire for calculations.

2. MRCGE-GTAP structure and simultaneous equations system

Many models exist within the world model by the concept of CGE in this paper. For overseas MRCGE, ORANI, developed by the Impact Project Monash University is a pioneering large-scale model (Dixon et al., 1982) of the Australian economy. It is divided into 112 sectors and 56 regions. The ORANI-G model is a more generalized variation (Horridge et al., 2000). Furthermore, many models have been developed recently, such as CG Europe (Bröcker, 1998), Pingo (Ivanova et al., 2002), RAEM (Thissen MJPM, 2004), MONASH-MRF (Peter et al., 1996), and MMRF-GREEN (Philip et al., 2000). These are applied to analyses of international trade policy, environmental policy, transportation policy, and so on. Moreover, the FEDERAL-F model is useful for analyses of fiscal policy, whereas MONASH-MRF and MMRF-

GREEN are for resource and environmental policy analyses (Giesecke, 2000). Furthermore, SinoTERM, based on the TERM model developed by Impact Project of Monash University (Horridge et al., 2003), has been developed for analyses of the Chinese economy (Horridge et al., 2008).

As described in this paper, GTAP-E, a world economic model used to analyze the effect of GHG discharge reduction policy can express the overseas relations. Hereinafter, the world model produced for this research has an even more simplified structure of fundamental GTAP. It might be appropriate to call it Modified GTAP (MGTAP). For example, GTAP shall provide the service expressed with the difference of an FOB price and a CIF price in the global transportation sector. However, for this study, it is assumed on the implicitness reverse side that the international transportation price is fixed.

2.1. Domestic production section of foreign countries. The structure of domestic production section of c country is portrayed in Figure 7. Optimization problems (P.9)-(P.10) are presented below.

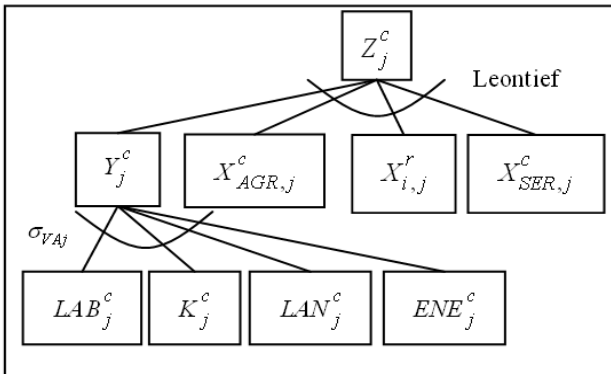

Fig. 7. Structure of domestic production section

$$\begin{cases} \max_{LAB_j^c, K_j^c, LAN_j^c, ENE_j^c} \left[\begin{array}{l} P_{Y_j^c} Y_j^c \\ - (1 + \tau_{LAB_j^c}) P_{LAB_j^c} LAB_j^c - (1 + \tau_{K_j^c}) P_{K_j^c} K_j^c \\ - (1 + \tau_{LAN_j^c}) P_{LAN_j^c} LAN_j^c \\ - (1 + \tau_{ENE_j^c}) P_{ENE_j^c} ENE_j^c \end{array} \right] \\ \text{s.t. } Y_j^c = \alpha_{VA_j^c} \left[\begin{array}{l} \beta_{LAB_j^c} LAB_j^c \frac{\sigma_{VA_j^c} - 1}{\sigma_{VA_j^c}} + \beta_{K_j^c} K_j^c \frac{\sigma_{VA_j^c} - 1}{\sigma_{VA_j^c}} \\ + \beta_{LAN_j^c} LAN_j^c \frac{\sigma_{VA_j^c} - 1}{\sigma_{VA_j^c}} \\ + \beta_{ENE_j^c} ENE_j^c \frac{\sigma_{VA_j^c} - 1}{\sigma_{VA_j^c}} \end{array} \right] \end{cases} \quad (\text{P.9})$$

$$\begin{cases} \max_{Y_j^c, X_{ij}^c} P_{Z_j^c} Z_j^c - P_{Y_j^c} Y_j^c - \sum_i (1 + \tau_{X_{ij}^c}) P_{X_{ij}^c} X_{ij}^c \\ \text{s.t. } Z_j^c = \min \left[\frac{Y_j^c}{\alpha_{Y_j^c}}, \frac{X_{AGR,j}^c}{\alpha_{X_{AGR,j}^c}}, \dots, \frac{X_{SER,j}^c}{\alpha_{X_{SER,j}^c}} \right] \end{cases} \quad (\text{P.10})$$

2.2. Household consumption section of foreign countries. The structure of household consumption section of c country is presented in Figure 8 along with the optimization problem (P.11).

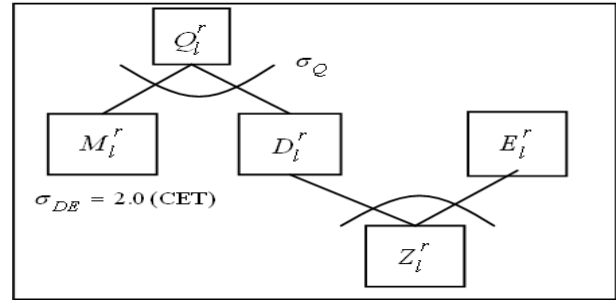

Fig. 8. Structure of household consumption section

$$\begin{cases} \max_{XH_i^c} UH^c = \left[\sum_{i \in I} \beta_{H_i^c} \frac{1}{\sigma_{H_i^c}} XH_i^c \frac{\sigma_{H_i^c} - 1}{\sigma_{H_i^c}} \right]^{\frac{\sigma_H}{\sigma_H - 1}} \\ \text{s.t. } P_{LAB^c} F_{LAB^c} + P_{K^c} F_{K^c} + P_{LAN^c} F_{LAN^c} + P_{ENE^c} F_{ENE^c} - HS^c = \\ = \sum_{i \in I} (1 + \tau_{H_i^c}) P_{Q_i^c} XH_i^c \end{cases} \quad (\text{P.11})$$

2.3. Government section of foreign countries. The structure of government expenditure and investment section of c country is presented in Figure 9 and Figure 10. Optimization problems (P.12)-(P.13) are shown below.

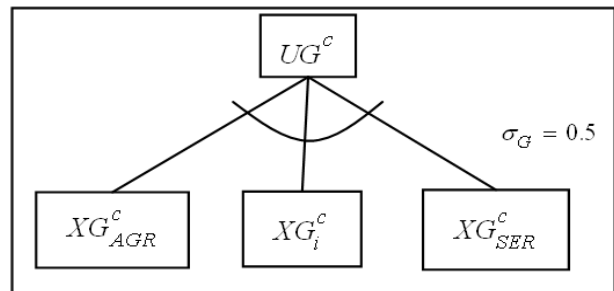

Fig. 9. Structure of government expenditure

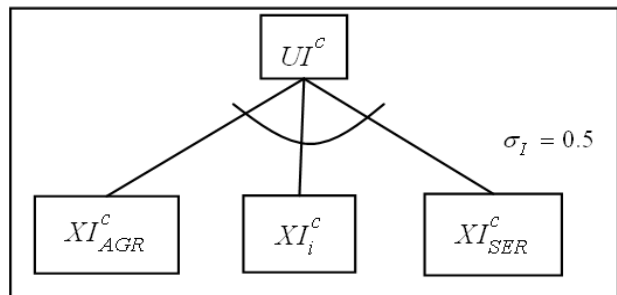

Fig. 10. Structure of government investment

$$\begin{aligned}
 \max_{XG_i^c} UG^c &= \left[\sum_{i \in I} \beta_{G_i^c} \frac{1}{\sigma_G} XG_i^c \frac{\sigma_G - 1}{\sigma_G} \right]^{\frac{\sigma_G}{\sigma_G - 1}} \\
 \text{s.t.} \sum_{j \in J} &\left(TLAB_j^c + TK_j^c + TLAN_j^c \right) + \sum_{i \in I} \sum_{j \in J} TX_{ij}^c + TD^c + \\
 &+ \sum_{i \in I} (TH_i^c + TEJ_i^c + TMJ_i^c) \\
 &+ \sum_{f \in C} \sum_{i \in I} (TE_i^{c,fc} + TM_i^{c,fc}) - GS^c = \\
 &= \sum_{i \in I} P_{Q_i^c} XG_i^c
 \end{aligned} \quad (P.12)$$

$$\begin{aligned}
 \max_{XI_i^c} .UI^c &= \left[\sum_{i \in I} \beta_{I_i^c} \frac{1}{\sigma_I} XI_i^c \frac{\sigma_I - 1}{\sigma_I} \right]^{\frac{\sigma_I}{\sigma_I - 1}} \\
 \text{s.t.} HS^c + GS^c + \varepsilon^c SF^c &= \sum_{i \in I} P_{Q_i^c} XI_i^c
 \end{aligned} \quad (P.13)$$

2.4. Export and domestic modification / import and domestic substitution of foreign countries.

The structure of export and domestic modification / import and domestic substitution of c country is shown in Figure 11 along with associated optimization problems (P.14)-(P.17). Moreover, σ_Q is approximately equal to the value of Appendix, Table 2A. Furthermore, $2\sigma_{DE}$ is used for modification of the elasticity of the transformation function by Ho-
soe et al. (2010).

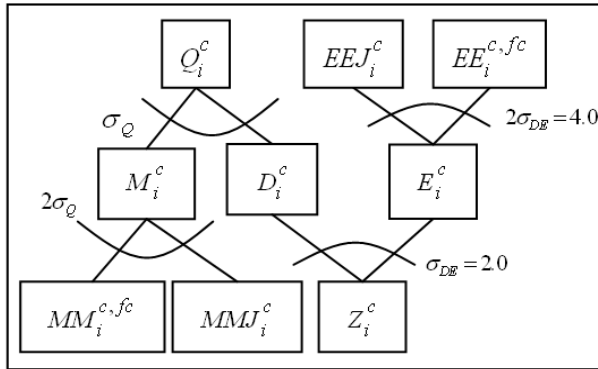

Fig. 11. Structure of export and import

$$\begin{aligned}
 \max_{D_i^c, E_i^c} P_{D_i^c} D_i^c + P_{E_i^c} E_i^c - (1 + \tau_{Z_i^c}) P_{Z_i^c} Z_i^c \\
 \text{s.t.} Z_i^c = \alpha_{DE_i^c} \left[\beta_{D_i^c} D_i^c \frac{\sigma_{DE} + 1}{\sigma_{DE}} + \beta_{E_i^c} E_i^c \frac{\sigma_{DE} + 1}{\sigma_{DE}} \right]^{\frac{\sigma_{DE}}{\sigma_{DE} + 1}},
 \end{aligned} \quad (P.14)$$

$$\begin{aligned}
 \max_{EE_i^{c,fc}, EEJ_i^c} \sum_{f \in C} (1 - \tau_{EE_i^{c,fc}}) P_{EE_i^{c,fc}} EE_i^{c,fc} + \\
 + (1 - \tau_{EEJ_i^c}) P_{EEJ_i^c} EEJ_i^c - P_{E_i^c} E_i^c \\
 \text{s.t.} E_i^c = \alpha_{E_i^c} \left[\sum_{f \in C} \beta_{EE_i^{c,fc}} EE_i^{c,fc} \frac{2\sigma_{DE} + 1}{2\sigma_{DE}} + \beta_{EEJ_i^c} EEJ_i^c \frac{2\sigma_{DE} + 1}{2\sigma_{DE}} \right]^{\frac{2\sigma_{DE}}{2\sigma_{DE} + 1}},
 \end{aligned} \quad (P.15)$$

$$\begin{aligned}
 \max_{MM_i^{c,fc}, MMJ_i^c} P_{M_i^c} M_i^c - \sum_{f \in C} P_{MM_i^{c,fc}} MM_i^{c,fc} - P_{MMJ_i^c} MMJ_i^c \\
 \text{s.t.} M_i^c = \alpha_{M_i^c} \left[\sum_{f \in C} \beta_{MM_i^{c,fc}} MM_i^{c,fc} \frac{\sigma_{M_i^c} - 1}{\sigma_{M_i^c}} + \beta_{MMJ_i^c} MMJ_i^c \frac{\sigma_{M_i^c} - 1}{\sigma_{M_i^c}} \right]^{\frac{\sigma_{M_i^c}}{\sigma_{M_i^c} - 1}},
 \end{aligned} \quad (P.16)$$

$$\begin{aligned}
 \max_{D_i^c, M_i^c} P_{Q_i^c} Q_i^c - P_{D_i^c} D_i^c - P_{M_i^c} M_i^c \\
 \text{s.t.} Q_i^c = \alpha_{DM_i^c} \left[\beta_{DD_i^c} D_i^c \frac{\sigma_{Q_i^c} - 1}{\sigma_{Q_i^c}} + \beta_{M_i^c} M_i^c \frac{\sigma_{Q_i^c} - 1}{\sigma_{Q_i^c}} \right]^{\frac{\sigma_{Q_i^c}}{\sigma_{Q_i^c} - 1}}.
 \end{aligned} \quad (P.17)$$

2.5. Market equilibrium conditions of foreign countries. Finally, a conditional expression for the demand of goods and factors of production and supply to be balanced in each market is assumed (see Appendix, equation (10)).

2.6. Equilibrium conditions between MRCGE and MRCGE-GTAP. As described herein, MRCGE and GTAP are interlocked with the equation for international trade (see Appendix, equation (11)).

2.7. Categorizations of regions and industries of MRCGE-GTAP. The categorizations of regions and industries are shown respectively in Table 1 and in Table 2A in Appendix. Especially, regarding categorization of a region, existing emissions trading schemes should be examined.

Table 1. Category of region

Notation of region	Country or region
ANZ	Australia, New Zealand
CHN	China, Hong Kong
JPN	Japan
KTW	Korea, Taiwan
THA	Thailand
ASA	Indonesia, Malaysia, the Philippines, Singapore, Vietnam, Bangladesh, India, Sri Lanka, South Asia
USA	United States
CAN	Canada
EU27	European Union 27 (Belgium, Bulgaria, Czechoslovakia, Denmark, Germany, Estonia, Greece, Spain, France, Ireland, Italy, Cyprus, Latvia, Lithuania, Luxembourg, Malta, Hungary, the Netherlands, Austria, Poland, Portugal, Romania, Slovakia, Slovenia, Finland, Sweden, the UK)
FSU	Russia and Former Soviet Union (Ukraine, Belarus, Kazakhstan, Tajikistan, Uzbekistan, Kyrgyz, Turkmenistan, Armenia, Azerbaijan, Moldova, Georgia)
ROW	Rest of the world

3. Simulation of Global Emissions Trading Scheme

Stern (2008) proposes international Cap and Trade (C&T) systems as an alternative to the Kyoto Protocol for three reasons: (1) they manage risks of dangerous climate change by imposing absolute limits on emission; (2) they reduce the costs of action; and (3)

they generate private sector financial flows to developing countries, which is useful for low carbon development. In simulations, a GETS was introduced in 2013 with credible commitment to keep it in place over the long run. Therefore, we take the Den Elzen and Hohne (2008) 450 ppm scenario, which produces emissions in 2020 that are 25% above those of 1990.

The European Union Emissions Trading Scheme (EU-ETS) using C&T is already conducted in EU. Furthermore, the Regional Greenhouse Gas Initiative and the Western Climate Initiative were announced, and the every place region in the world aims at introduction of C&T. The Emissions Trading policy, Japan's Voluntary Emissions Trading Scheme (J-VETS), has also started already. However, these emissions trading schemes are fundamentally addressing domestic markets. For that reason, it is understood that the difference of Marginal Abatement Cost (MAC) is large and inefficient from the viewpoint of cost efficiency. Therefore, a GETS that gives zero deadweight loss generated from scheme inefficiency is desired. As described herein, a policy simulation that includes effects by the design of institutional arrangements of GETS is performed. We begin by assessing the Kyoto-type framework, which sets emissions targets for developed countries and no targets for developing countries from economic and environmental perspectives using MRCGE-GTAP. We then consider GETS as an alternative to the Kyoto Protocol and assess GETS from economic and environmental perspectives.

3.1. Setting of scenario of GETS. The Embassy of Japan has submitted to the secretariat information related to its quantified economy-wide emissions target for 2020 of the Copenhagen Accord as described below. A 25% reduction (base year 1990) was agreed to premised on the establishment of a fair and effective international framework in which all major economies participate and on agreement by those economies on ambitious targets.

- ◆ Scenario 1: GETS without case.
- ◆ Scenario 2: GETS with case.
- ◆ Scenario 3: GETS with case (Japan is excluded).

Table 2. Settings of GETS

Setup in MRCGE-GTAP	
Setting of emissions	Direct discharge of chemicals, iron or steel articles, three other material segments of industry of the manufacturing industry, and electric power.
Treatment of electric power	Indirect discharge (in the model, because it is discharged directly, although the dealings market of direct discharge is set up, electric power is dealt with by indirect discharge by setting up the market independent in each segment of industry)
Setting method of emissions	Gratis assignment (in the model, an auction income is returned to each segment of industry as a product subsidy as an auction system according to the purchase ratio of emissions)
Quantity of emissions (Simulation case)	* The 90-year GHG discharge amount of Japan is ▲ 25% (05 year ▲ 26.7%),

	* Data of foreign countries are inferred as the Copenhagen accord bases. N.Z.: 00 year▲ 15% (05 year ▲ 25.8%) U.S.: 05 year ▲ 17% Canada: 05 year ▲ 17% EU27: 90 year ▲ 20% (05 year ▲ 14%) FSU: 05 year▲ 0%
Enforcement year (base year)	2005

Notes: ▲ means minus.

3.2. Simulation and results. Generalization of a simulation result is presented in Table 3. Scenario 2 means that about 12,000 (yen/tCO₂) is the market price that is the optimal international market price; a social surplus generates MAC through GETS. On the other hand, for each country to attain the GHG emissions reduction independently based on the Copenhagen accord, a difference produces Scenario 1 in MAC by the industrial structure and trade structure in respective countries. Results show that in Japan, the trial calculation of the about 31,000 (yen/tCO₂) minimum of Australia and New Zealand market was made for the maximum of about 93,000 (yen/tCO₂) and other markets with about 13,000 (yen/tCO₂) of the U.S. market. Moreover, in Scenario 3, Japan is dealt with by about 92,000 (yen/tCO₂), and is set to about 10,000 (yen/tCO₂) under GETS. Because MAC is very high, when Japan participates in GETS, the country has a negative social benefit by market mechanisms generates Japan which has environmental reduction technology of the highest level.

Figure 12 shows the real GDP growth rate of change by country. The rate of change of a FSU market is remarkable also in which scenario so that clearly from this figure.

The change of social welfare as classified by country is shown in Figure 13 according to the scenario. For KTW, the USA, EU27, and ROW markets, social welfare is greatly decreased. This is regarded as reflecting the influence by which MAC throughout the world increased when high-MAC Japan came to participate in GETS in Scenario 2.

Moreover, Figure 14 shows that the value of production of energy-intensive industries, such as electric power, gas, heat supply, increases. For this reason, the steep rise in product prices has greater influence than the quantity of production. The rise of product prices influences the consumer goods price, thereby reducing social welfare.

Figure 15 shows the real GRP growth rate of change. For scenario 1 and Scenario 3, the real GRP rate of change is large. For Scenario 2, the change width becomes small. Moreover, in Scenario 1 and Scenario 3, the sizes of influence differ for every all prefectures because of the influence of environmental change related to international trade.

Table 3. Generalization of simulation results

Scenario Index (2005 price)		Scenario 1 GETS without case	Scenario 2 GETS with case	Scenario 3 GETS with case (Japan is excluded)	
Above 1990 GHG emission 25% reduction (above 2005, 26.7% reduction)	Quantity of GHG trading in Japan (million-tCO ₂)	–	191.72	–	
	Marginal abatement cost (Yen/tCO ₂)	Maximum (another market)	30,699 (ANZ market price)	11,622 (International price)	10,306 (International price)
		Japan	93,194 (JPN market price)	11,622 (International price)	92,097 (JPN market price)
		Minimum (another market)	12,937 (USA market price)	11,622 (International price)	10,306 (International price)

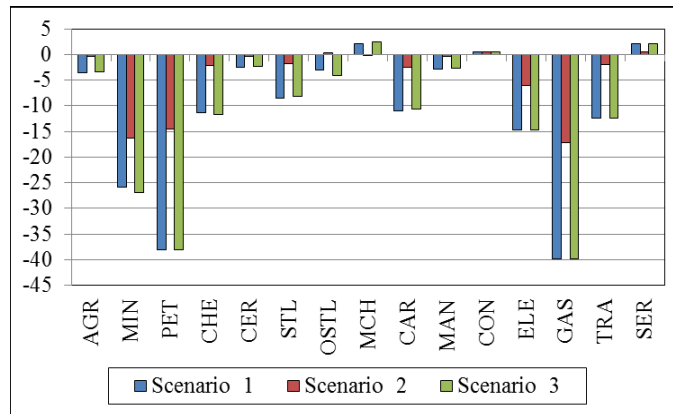

Fig. 12. Real GDP growth rate (%)

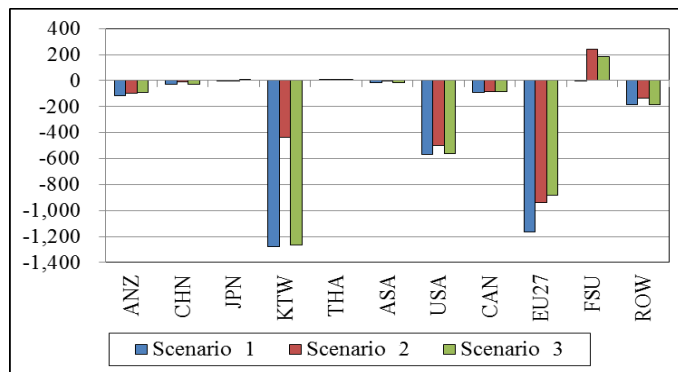

Fig. 13. Change of social welfare per capita (Yen: 2005 price)

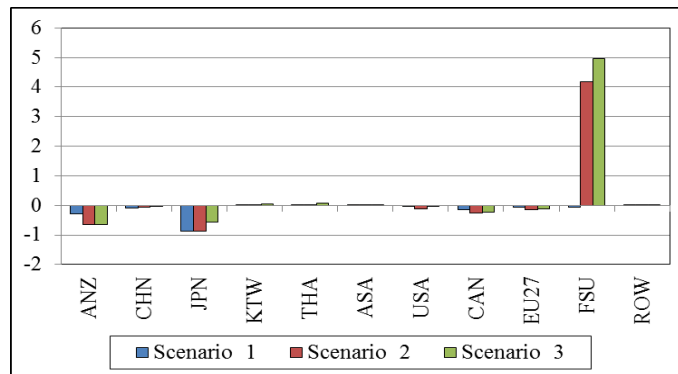

Fig. 14. Rate of change of the quantity of production in Japan (%)

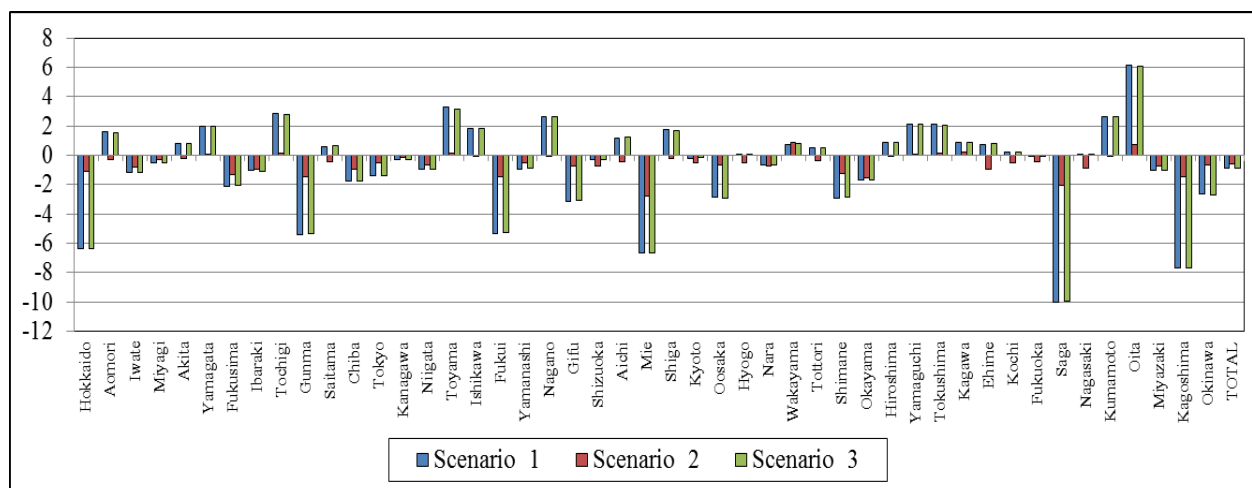

Fig. 15. Real GRP growth rate in Japan (%)

Conclusion

This study developed MRCGE-GTAP, which explicitly expresses the relation between Japan and the world economy. The GETS international GHG discharge reduction policy was simulated using MRCGE-GTAP. The international effects and economic efficiency of this system were examined. Conclusions inferred from the simulation results of GETS scheme as international GHG discharge reduction policy are presented below. The simulation results verified that social public welfare is maximized when all countries and regions participate in GETS. To promote a GHG emissions reduction policy maintainable by the world, it was clarified that some measure of international cooperation is indispensable.

References

1. Armington, P.S. (1969). A Theory of Demand for Products Distinguished by Place of Production, *International Monetary Fund Staff Papers*, Vol. 16, pp. 159-176.
2. Ban, K. (2007). Forward Looking Dynamic Multiregional CGE Model for Japanese Economy, *RIETI Discussion Paper Series*, 07-J-043, pp. 1-52.
3. Bröcker, J. (1998). Operational Spatial Computable General Equilibrium Modelling, *The Annals of Regional Science*, Vol. 32, No. 3, pp. 367-387.
4. Burniaux, J.-M. and T.P. Truong (2001). GTAP-E: An Energy-Environmental Version of the GTAP Model, *GTAP Technical Paper*, No. 16.
5. Den Elzen, M. and N. Hohne (2008). Reductions of Greenhouse Gas Emissions in Annex I and non-Annex I Countries for Meeting Concentrations Stabilization Targets, *Climate Change*, Vol. 92, pp. 249-274.
6. Dixon, P.D., B.R. Parmenter, J. Sutton and D.P. Vincent (1982). *ORANI: A Multi-Sectoral Model of the Australian Economy*, North-Holland.
7. Fischer, C. and A.K. Fox (2007). Output-Based Allocation of Emissions Permits for Mitigating Tax and Trade Interactions, *Land Economics*, Vol. 83, No. 4, pp. 575-599.
8. Giesecke, J.A.D. (2000). The Theoretical Structure of the Federal-F Model, *CREA Paper*, No. TS-08, Center for Regional Economic Analysis, University of Tasmania, Australia.
9. Hayashiyama, Y., M. Abe and S. Muto (2012). Evaluation of GHG Discharge Reduction Policy: By 47 Prefectures Multi-Regional CGE, *Journal of Applied Regional Science* (in Press).
10. Hertel, T.W. and M.E. Tsigas (1997). *Structure of GTAP, Global Trade Analysis: Modeling and Applications*, Cambridge University Press.
11. Horridge, J.M., B.R. Parmenter and K.R. Pearson (2000). *ORANI-G: A General Equilibrium Model of the Australian Economy*, Center of Policy Studies and Impact Project, Monash University, Australia.
12. Horridge, M. and G. Wittwer (2008). SinoTERM, A Multi-Regional CGE Model of China, *China Economic Review*, Vol. 19, pp. 628-634.

Moreover, it is necessary to adjust future subjects with sensitivity analysis of MRCGE-GTAP. Furthermore, in a simulation result, change in market prices might have increased the influence of tax-base effects and tax-interaction effects by the GHG emissions trading scheme. More detailed examinations of these points are required.

Acknowledgements

This study was financially supported as “Policy Research of Environmental Economics FY2009-2011” by the Ministry of the Environment. We gratefully acknowledge their generosity and helpful comments from associated academic contributors.

13. Horridge, M., J. Madden and G. Wittwer (2003). Using a Highly Disaggregated Multi-Regional Single-Country Model to Analyse the Impacts of the 2002-03 drought on Australia, *Centre of Policy Studies/IMPACT Center Working Papers*, No. G-141.
14. Hosoe, N., K. Gasawa and H. Hashimoto (2010). *Textbook of Computable General Equilibrium Modeling*, Palgrave Macmillan.
15. Ianchovichina, R. and R. McDougall (2000). Structure of Dynamic GTAP, *GTAP Technical Paper*, No. 18.
16. Ivanova, O., A. Volid and V.J. Hansen (2002). Pingo – A Model for Prediction of Regional and Interregional Freight Transport: Version 1, Institute of Transport Economics, *Oslo*, TØI Report 578.
17. Ministry of the Environment of Japan (2010). *Japan Emission Trading Scheme: Middle Proposal*, Sub-Committee on Japan Emission Trading Scheme, Global Environment Committee, Central Environment Council Ministry of the Environment of Japan, pp. 1-96 (in Japanese).
18. Narayanan, G. and T.L. Walmsley eds. (2008). *Global Trade, Assistance, and Production: The GTAP7 Data Base*, Center for Global Trade Analysis, Department of Agricultural Economics, Purdue University.
19. Peter, M.W., M. Horridge, G.A. Meagher, F. Naqvi and B.R. Parmenter (1996). The Theoretical Structure of MONASH-MRF, *Center of Policy Studies/IMPACT Center Working Papers*, No. OP-85.
20. Philip, D.J., J.M. Horridge and B.R. Parmenter (2000). MMRF-GREEN: A Dynamic, Multi-Sectorial, Multi-Regional Model of Australia, *Center of Policy Studies/IMPACT Centre Working Papers*, No. OP-94.
21. Rutherford, T.F. and S.V. Paltsev (2000). GTAP in GAMS and Gtap-EG: Global Datasets for Economic Research and Illustrative Models, *Working Paper*, Department of Economics, University Colorado, pp. 1-64.
22. Stern, N. (2008). *Key Elements of Global Deal on Climate Change*, London School of Economics and Political Science.
23. Thissen, M.J.P.M. (2004). REAM 2.0: A Regional Applied General Equilibrium Model for the Netherlands, TNO Working Paper.

Appendix

1. Notation of subscripts

$r (r \in R)$, $s (s \in S)$: Region (47 prefectures)

$i (i \in I)$, $j (j \in J)$: Industry (15 industries)

$c, fc (c, fc \in C, c \neq fc, JPN \notin C)$: Country \times Region

Table 1A. Notation of variables

Variables	Explanation
$P_{Y_j^s}, P_{Y_j^c}$	Composite production factor price
$P_L^s, P_{LAB_j^c}$	Labor price
$P_{K^s}, P_{K_j^c}$	Capital stock price
$P_{X_{ij}^s}, P_{X_{ij}^c}$	Composite intermediate input goods price
$P_{Q_i^r}, P_{Q_i^c}$	Armington composite goods price
$P_{Z_j^s}, P_{Z_j^c}$	Domestic production goods price
Y_j^s, Y_j^c	Composite production goods factor
L_j^s, LAB_j^c	Labor
K_j^s, K_j^c	Capital stock
X_{ij}^s, X_{ij}^c	Composite intermediate input goods
Q_i^r, Q_i^c	Armington composite goods
Z_j^s, Z_j^c	Domestic production goods
XX_{ij}^{rs}	Intermediate input goods
$\alpha_{Y_j^s}, \alpha_{X_{ij}^s}, \alpha_{Y_j^c}, \alpha_{X_{ij}^c}$	Input parameter

$\alpha_{LK_j^s}, \alpha_{XX_{ij}^s}, \alpha_{VA_j^c}$	Scale parameter
--	-----------------

Table 1A (cont.). Notation of variables

Variables	Explanation
$\beta_{L_j^s}, \beta_{K_j^s}, \beta_{XX_{ij}^s}, \beta_{K_j^c}, \beta_{LAB_j^c}, \beta_{LAN_j^c}, \beta_{ENE_j^c}$	Share parameter $(\beta_{L_j^s} + \beta_{K_j^s} = 1, \sum_{r \in R} \beta_{XX_{ij}^s} = 1)$ $(\beta_{K_j^c} + \beta_{LAB_j^c} + \beta_{LAN_j^c} + \beta_{ENE_j^c} = 1)$
$\sigma_{VA_j}, \sigma_X, \sigma_{VA_j^c}$	Elasticity of substitution parameter $(\sigma_{VA_j} = \sigma_{VA_j^c})$
P_{LAN^c}	Land price
P_{ENE^c}	Energy-resource goods price
LAN_j^c	Land
ENE_j^c	Energy-resource goods
$TLAB_j^c$	Labor tax
$TLAN_j^c$	Land tax
$TENE_j^c$	Energy-resource tax
$\tau_{K_j^c}$	Rate of capital stock
$\tau_{LAB_j^c}$	Rate of labor tax
$\tau_{LAN_j^c}$	Rate of land tax
$\tau_{ENE_j^c}$	Rate of energy-resource tax
UH^s, UH^c	Utility level of households
XH_i^{rs}, XH_i^c	Household consumption goods
$F_{L_j^s}, F_{LAB_j^c}$	Labor (initial) quantity of households
$F_{K_j^s}, F_{K_j^c}$	Capital (initial) quantity of households
TD^s, TD^c	Direct tax
TH_i^c	Consumption tax
HS^s, HS^c	Saving of households
τ_D^s, τ_D^c	Direct tax rate
$\tau_{H_i^c}$	Consumption tax rate
$\delta_{HS}^s, \delta_{HS^c}$	Saving rate of households
$\beta_{XH_i^{rs}}, \beta_{XH_i^c}$	Share parameter $(\sum_{r \in R} \sum_{i \in I} \beta_{XH_i^{rs}} = 1, \sum_{i \in I} \beta_{XH_i^c} = 1)$
σ_H	Elasticity of substitution parameter
EV^s	Equivalent variation
XH_i^s	Composite consumption goods vector
$\overline{UH_i^s(XH_i^s)}$	Utility level of households (exogenous)
$E_i^s(\cdot)$	Expenditure function

p_t^s	Composite consumption goods price vector
$t = 0, 1$	Enforcement existence

Table 1A (cont.). Notation of variables

Variables	Explanation
UG^s, UG^c	Virtual utility level of government section
XG_i^{rs}, XG_i^c	Governmental consumption goods
TZ_j^s, TZ_j^c	Production tax
TM_j^s, TH_i^c	Tariff payment
GS^s, GS^c	Saving of government
$\tau_{Z_j^s}, \tau_{Z_j^c}$	Production tax rate
$\tau_{M_j^s}, \tau_{H_i^c}$	Tariff rate
$\delta_{GS}^s, \delta_{GS}^c$	Saving rate of government
$\beta_{XG_i^{rs}}, \beta_{G_i^c}$	Share parameter ($\sum_{r \in R} \sum_{i \in I} \beta_{XG_i^{rs}} = 1, \sum_{i \in I} \beta_{G_i^c} = 1$)
σ_G	Elasticity of substitution parameter
UI^s, UI^c	Virtual utility level of investment section
XI_i^{rs}, XI_i^c	Investment goods
SF^s, SF^c	Foreign savings
$E_j^s, E_i^c, EE_i^{c,jc}, EEJ_i^c$	Export
$M_j^s, M_i^c, MM_i^{c,jc}, MMJ_i^c$	Import
$PW_{E_j}, P_{WE_i^c}$	International export goods price
$PW_{M_j}, P_{WM_i^c}$	International import goods price
TR^s	Transfer income
$\varepsilon, \varepsilon^c$	Exchange rate denominated in foreign currency
$\beta_{XI_i^{rs}}, \beta_{I_i^c}$	Share parameter ($\sum_{r \in R} \sum_{i \in I} \beta_{XI_i^{rs}} = 1, \sum_{i \in I} \beta_{I_i^c} = 1$)
σ_I	Elasticity of substitution parameter
D_i^r, D_i^c	Supply of domestic composite goods
$P_{D_i^r}, P_{D_i^c}$	Domestic composite goods price
$P_{E_i^r}, P_{E_i^c}, P_{EE_i^{c,jc}}, P_{EEJ_i^c}$	Export goods price
$P_{M_i^r}, P_{M_i^c}, P_{MM_i^{c,jc}}, P_{MMJ_i^c}$	Import goods price
$\alpha_{DE_i^r}, \alpha_{DM_i^r}, \alpha_{DE_i^c}, \alpha_{DM_i^c}, \alpha_{E_i^r}, \alpha_{M_i^r}$	Scale parameter
$\beta_{DD_i^r}, \beta_{M_i^r}, \beta_{D_i^r}, \beta_{E_i^r}, \beta_{DD_i^c}, \beta_{M_i^c}, \beta_{D_i^c}, \beta_{E_i^c}, \beta_{EEJ_i^c}, \beta_{MMJ_i^c}, \beta_{EE_i^{c,jc}}, \beta_{EEJ_i^c}$	Share parameter ($\beta_{DD_i^r} + \beta_{M_i^r} = 1, \beta_{D_i^r} + \beta_{E_i^r} = 1, \beta_{D_i^c} + \beta_{E_i^c} = 1, \beta_{DD_i^c} + \beta_{M_i^c} = 1,$ $\beta_{EEJ_i^c} + \sum_{jc \in C} \beta_{EE_i^{c,jc}} = 1, \beta_{MMJ_i^c} + \sum_{jc \in C} \beta_{MM_i^{c,jc}} = 1$)
$\sigma_{DE}, \sigma_{Q_i}$	Elasticity of substitution parameter

2. Simultaneous equations system

1. Domestic production section:

$$Y_j^s = \alpha_{LK_j^s} \left[\beta_{L_j^s} L_j^s \frac{\sigma_{VA_j}-1}{\sigma_{VA_j}} + \beta_{K_j^s} K_j^s \frac{\sigma_{VA_j}-1}{\sigma_{VA_j}} \right] \frac{\sigma_{VA_j}}{\sigma_{VA_j}-1}, \quad (1)$$

$$L_j^s = \left[\frac{\alpha_{LK_j^s} \beta_{L_j^s} P_{Y_j^s}}{P_{L^s}} \right]^{\sigma_{VA_j}} \frac{Y_j^s}{\alpha_{LK_j^s}}, \quad (2)$$

$$K_j^s = \left[\frac{\alpha_{LK_j^s} \beta_{K_j^s} P_{Y_j^s}}{P_{K^s}} \right]^{\sigma_{VA_j}} \frac{Y_j^s}{\alpha_{LK_j^s}}, \quad (3)$$

$$X_{ij}^s = \alpha_{XX_{ij}^s} \left[\sum_{r \in R} \beta_{XX_{ij}^s} X_{ij}^{rs} \frac{\sigma_X-1}{\sigma_X} \right]^{\sigma_X} \frac{\sigma_X}{\sigma_X-1}, \quad (4)$$

$$XX_{ij}^{rs} = \left[\frac{\alpha_{XX_{ij}^s} \beta_{XX_{ij}^s} P_{X_{ij}^s}}{P_{Q_i^r}} \right]^{\sigma_X} \frac{X_{ij}^s}{\alpha_{XX_{ij}^s}}, \quad (5)$$

$$Y_j^s = \alpha_{Y_j^s} Z_j^s, \quad (6)$$

$$X_{ij}^s = \alpha_{X_{ij}^s} Z_{ij}^s, \quad (7)$$

$$P_{Z_j^s} = P_{Y_j^s} \alpha_{Y_j^s} + \sum_{i \in I} P_{X_{ij}^s} \alpha_{X_{ij}^s}. \quad (8)$$

2. Household consumption section:

$$XH_i^{rs} = \frac{\beta_{XH_i^{rs}} \left[P_{L^s} F_{L^s} + P_{K^s} F_{K^s} - TD^s - HS^s \right]}{P_{Q_i^r}^{\sigma_H} \left(\sum_{i \in I} \beta_{XH_i^{rs}} P_{Q_i^r}^{(1-\sigma_H)} \right)}, \quad (9)$$

$$TD^s = \tau_D \left[P_{L^s} F_{L^s} + P_{K^s} F_{K^s} \right], \quad (10)$$

$$HS^s = \delta_{HS}^s \left[P_{L^s} F_{L^s} + P_{K^s} F_{K^s} \right], \quad (11)$$

$$E_i^s \left(p_0^s, \overline{UH_i^s(XH_i^s)} \right) \equiv \min_{XH_i^s} \left[p_0^s \cdot XH_i^s \mid UH_i^s(XH_i^s) \right], \quad (12)$$

$$EV^s \equiv E_1^s \left(p_0^s, UH_1^s(XH_1^s) \right) - E_0^s \left(p_0^s, UH_0^s(XH_0^s) \right). \quad (13)$$

3. Government section:

$$XG_i^{rs} = \frac{\beta_{XG_i^{rs}} \left(\sum_{j \in J} TZ_j^s + TD^s + \sum_{j \in J} TM_j^s - GS^s \right)}{P_{Q_i^r}^{\sigma_G} \sum_{i \in I} \beta_{XG_i^{rs}} P_{Q_i^r}^{(1-\sigma_G)}}, \quad (14)$$

$$TZ_j^s = \tau_{Z_j^s} P_{Z_j^s} Z_j^s, \quad (15)$$

$$TM_j^s = \tau_{M_j^s} P_{M_j^s} M_j^s, \quad (16)$$

$$GS^s = \delta_{GS}^s \left(\sum_{j \in J} TZ_j^s + \sum_{j \in J} TM_j^s + TD^s \right), \quad (17)$$

$$XI_i^{rs} = \frac{\beta_{XI_i^{rs}} (HS^s + GS^s + \varepsilon SF^s + TR^s)}{P_{Q_i^r}^{\sigma_1} \sum_{i \in I} \beta_{XI_i^{rs}} P_{Q_i^r}^{(1-\sigma_1)}}, \quad (18)$$

$$SF^s = \sum_{j \in J} (PW_{M_j} M_j^s - PW_{E_j} E_j^s), \quad (19)$$

$$TR^s = \sum_{r \in R} \sum_{i \in I} P_{Q_i^r} XI_i^{rs} - HS^s - GS^s - \varepsilon SF^s. \quad (20)$$

4. Export and domestic modification / import and domestic substitution:

$$Z_i^r = \alpha_{DE_i^r} \left[\beta_{D_i^r} D_i^r \frac{\sigma_{DE}+1}{\sigma_{DE}} + \beta_{E_i^r} E_i^r \frac{\sigma_{DE}+1}{\sigma_{DE}} \right] \frac{\sigma_{DE}}{\sigma_{DE}+1}, \quad (21)$$

$$E_i^r = \left[\frac{\alpha_{DE_i^r} \beta_{E_i^r} (1 + \tau_{Z_i^r}) P_{Z_i^r}}{P_{E_i^r}} \right]^{-\sigma_{DE}} \frac{Z_i^r}{\alpha_{DE_i^r}}, \quad (22)$$

$$D_i^r = \left[\frac{\alpha_{DE_i^r} \beta_{D_i^r} (1 + \tau_{Z_i^r}) P_{Z_i^r}}{P_{D_i^r}} \right]^{-\sigma_{DE}} \frac{Z_i^r}{\alpha_{DE_i^r}}, \quad (23)$$

$$Q_i^r = \alpha_{DM_i^r} \left[\beta_{DD_i^r} D_i^r \frac{\sigma_{Q_i} - 1}{\sigma_{Q_i}} + \beta_{M_i^r} M_i^r \frac{\sigma_{Q_i} - 1}{\sigma_{Q_i}} \right] \frac{\sigma_{Q_i}}{\sigma_{Q_i} - 1}, \quad (24)$$

$$D_i^r = \left[\frac{\alpha_{DM_i^r} \beta_{DD_i^r} P_{Q_i^r}}{P_{D_i^r}} \right]^{\sigma_{Q_i}} \frac{Q_i^r}{\alpha_{DM_i^r}}, \quad (25)$$

$$M_i^r = \left[\frac{\alpha_{DM_i^r} \beta_{M_i^r} P_{Q_i^r}}{(1 + \tau_{M_i^r}) P_{M_i^r}} \right]^{\sigma_{Q_i}} \frac{Q_i^r}{\alpha_{DM_i^r}}, \quad (26)$$

$$P_{E_i^r} = \varepsilon PW_{E_i}, \quad (27)$$

$$P_{M_i^r} = \varepsilon PW_{M_i}. \quad (28)$$

5. Market equilibrium conditions:

$$Q_i^r = \sum_{s \in S} \sum_{j \in J} XX_{ij}^{rs} + \sum_{s \in S} XH_i^{rs} + \sum_{s \in S} XG_i^{rs} + \sum_{s \in S} XI_i^{rs}, \quad (29)$$

$$\sum_{j \in J} L_j^s = F_{L^s}, \quad (30)$$

$$\sum_{j \in J} K_j^s = F_{K^s}, \quad (31)$$

$$\sum_{s \in S} TR^s = 0. \quad (32)$$

6. Domestic production section of foreign countries:

$$Y_j^c = \alpha_{VA_j^c} \left[\begin{array}{l} \beta_{LAB_j^c} LAB_j^c \frac{\sigma_{VA_j} - 1}{\sigma_{VA_j}} + \beta_{K_j^c} K_j^c \frac{\sigma_{VA_j} - 1}{\sigma_{VA_j}} \\ + \beta_{LAN_j^c} LAN_j^c \frac{\sigma_{VA_j} - 1}{\sigma_{VA_j}} \\ + \beta_{ENE_j^c} ENE_j^c \frac{\sigma_{VA_j} - 1}{\sigma_{VA_j}} \end{array} \right] \frac{\sigma_{VA_j}}{\sigma_{VA_j} - 1}, \quad (33)$$

$$LAB_j^c = \left[\frac{\alpha_{VA_j^c} \beta_{LAB_j^c} P_{Y_j^c}}{(1 + \tau_{LAB_j^c}) P_{LAB^c}} \right]^{\sigma_{VA_j}} \frac{Y_j^c}{\alpha_{VA_j^c}}, \quad (34)$$

$$K_j^c = \left[\frac{\alpha_{VA_j^c} \beta_{K_j^c} P_{Y_j^c}}{(1 + \tau_{K_j^c}) P_{K^c}} \right]^{\sigma_{VA_j}} \frac{Y_j^c}{\alpha_{VA_j^c}}, \quad (35)$$

$$LAN_j^c = \left[\frac{\alpha_{VA_j^c} \beta_{LAN_j^c} P_{Y_j^c}}{(1 + \tau_{LAN_j^c}) P_{LAN^c}} \right]^{\sigma_{VA_j}} \frac{Y_j^c}{\alpha_{VA_j^c}}, \quad (36)$$

$$ENE_j^c = \left[\frac{\alpha_{VA_j^c} \beta_{ENE_j^c} P_{Y_j^c}}{(1 + \tau_{ENE_j^c}) P_{ENE^c}} \right]^{\sigma_{VA_j}} \frac{Y_j^c}{\alpha_{VA_j^c}}, \quad (37)$$

$$Y_j^c = \alpha_{Y_j^c} Z_j^c, \quad (38)$$

$$X_{ij}^c = \alpha_{X_{ij}^c} Z_j^c, \quad (39)$$

$$P_{Z_j^c} = P_{Y_j^c} \alpha_{Y_j^c} + \sum_{i \in I} (1 + \tau_{X_{ij}^c}) P_{Q_i^c} \alpha_{X_{ij}^c}, \quad (40)$$

$$TLAB_j^c = \tau_{LAB_j^c} P_{LAB^c} LAB_j^c, \quad (41)$$

$$TK_j^c = \tau_{K_j^c} P_{K^c} K_j^c, \quad (42)$$

$$TLAN_j^c = \tau_{LAN_j^c} P_{LAN^c} LAN_j^c, \quad (43)$$

$$TENE_j^c = \tau_{ENE_j^c} P_{ENE^c} ENE_j^c, \quad (44)$$

$$TX_{ij}^c = \tau_{X_{ij}^c} P_{Q_i^c} X_{ij}^c. \quad (45)$$

7. Household consumption section of foreign countries:

$$XH_i^c = \frac{\beta_{H_i^c}}{(1 + \tau_{H_i^c})^{\sigma_H} P_{Q_i^c}^{\sigma_H}} \times \frac{\left[P_{LAB^c} F_{LAB^c} + P_{K^c} F_{K^c} + P_{LAN^c} F_{LAN^c} + P_{ENE^c} F_{ENE^c} - HS^c \right]}{\left(\sum_{i \in I} \beta_{H_i^c} (1 + \tau_{H_i^c})^{(1-\sigma_H)} P_{Q_i^c}^{(1-\sigma_H)} \right)^{(1-\sigma_H)}}, \quad (46)$$

$$HS^c = \delta_{HS^c} \left[\begin{array}{l} P_{LAB^c} F_{LAB^c} + P_{K^c} F_{K^c} \\ + P_{LAN^c} F_{LAN^c} + P_{ENE^c} F_{ENE^c} \end{array} \right], \quad (47)$$

$$TD^c = \tau_{D^c} \left[\begin{array}{l} P_{LAB^c} F_{LAB^c} + P_{K^c} F_{K^c} \\ + P_{LAN^c} F_{LAN^c} + P_{ENE^c} F_{ENE^c} \end{array} \right], \quad (48)$$

$$TH_i^c = \tau_{H_i^c} P_{Q_i^c} XH_i^c, \quad (49)$$

8. Government section of foreign countries:

$$XG_i^c = \frac{\beta_{G_i^c}}{P_{Q_i^c}^{\sigma_G} \left(\sum_{i \in I} \beta_{G_i^c} P_{Q_i^c}^{(1-\sigma_G)} \right)} \begin{bmatrix} \sum_{j \in J} \left(TLAB_j^c + TK_j^c + TLAN_j^c \right) \\ + TENE_j^c + TZ_j^c \\ + \sum_{i \in I} \sum_{j \in J} TX_{ij}^c + TD^c \\ + \sum_{i \in I} (TH_i^c + TEJ_i^c + TMJ_i^c) \\ + \sum_{j \in C} \sum_{i \in I} (TE_i^{c,jc} + TM_i^{c,jc}) \\ - GS^c \end{bmatrix}, \quad (50)$$

$$TZ_j^c = \tau_{Z_j^c} P_{Z_j^c} Z_j^c, \quad (51)$$

$$GS^c = \delta_{GS^c} \begin{bmatrix} \sum_{j \in J} \left(TLAB_j^c + TK_j^c + TLAN_j^c \right) \\ + TENE_j^c + TZ_j^c \\ + \sum_{i \in I} \sum_{j \in J} TX_{ij}^c + TD^c \\ + \sum_{i \in I} (TH_i^c + TEJ_i^c + TMJ_i^c) \\ + \sum_{j \in C} \sum_{i \in I} (TE_i^{c,jc} + TM_i^{c,jc}) \end{bmatrix}, \quad (52)$$

$$XI_i^c = \frac{\beta_{I_i^c} (HS^c + GS^c + \varepsilon^c SF^c)}{P_{Q_i^c}^{\sigma_I} \left(\sum_{i \in I} \beta_{I_i^c} P_{Q_i^c}^{(1-\sigma_I)} \right)}, \quad (53)$$

$$SF^c = \sum_{i \in I} \sum_{j \in C} \left(P_{WMM_i^{c,jc}} MM_i^{c,jc} - P_{WEE_i^{c,jc}} EE_i^{c,jc} \right) + \sum_{i \in I} \left(P_{WMJ_i^c} MMJ_i^c - P_{WEJ_i^c} EEJ_i^c \right). \quad (54)$$

9. Export and domestic modification/ import and domestic substitution of foreign countries:

$$Z_i^c = \alpha_{DE_i^c} \left[\beta_{D_i^c} D_i^c \frac{\sigma_{DE} + 1}{\sigma_{DE}} + \beta_{E_i^c} E_i^c \frac{\sigma_{DE} + 1}{\sigma_{DE}} \right]^{\frac{\sigma_{DE}}{\sigma_{DE} + 1}}, \quad (55)$$

$$E_i^c = \left[\frac{\alpha_{DE_i^c} \beta_{E_i^c} (1 + \tau_{Z_i^c}) P_{Z_i^c}}{P_{E_i^c}} \right]^{-\sigma_{DE}} \frac{Z_i^c}{\alpha_{DE_i^c}}, \quad (56)$$

$$D_i^c = \left[\frac{\alpha_{DE_i^c} \beta_{D_i^c} (1 + \tau_{Z_i^c}) P_{Z_i^c}}{P_{D_i^c}} \right]^{-\sigma_{DE}} \frac{Z_i^c}{\alpha_{DE_i^c}}, \quad (57)$$

$$E_i^c = \alpha_{E_i^c} \left[\begin{array}{l} \sum_{j \in W} \beta_{EE_i^{c,jc}} EE_i^{c,jc} \frac{2\sigma_{DE} + 1}{2\sigma_{DE}} \\ + \beta_{EEJ_i^c} EEJ_i^c \frac{2\sigma_{DE} + 1}{2\sigma_{DE}} \end{array} \right]^{\frac{2\sigma_{DE}}{2\sigma_{DE} + 1}}, \quad (58)$$

$$EE_i^{c,jc} = \left[\frac{\alpha_{E_i^c} \beta_{EE_i^{c,jc}} P_{E_i^c}}{(1 - \tau_{EE_i^{c,jc}}) P_{EE_i^{c,jc}}} \right]^{-2\sigma_{DE}} \frac{E_i^c}{\alpha_{E_i^c}}, \quad (59)$$

$$EEJ_i^c = \left[\frac{\alpha_{E_i^c} \beta_{EEJ_i^c} P_{E_i^c}}{(1 - \tau_{EEJ_i^c}) P_{EEJ_i^c}} \right]^{-2\sigma_{DE}} \frac{E_i^c}{\alpha_{E_i^c}}, \quad (60)$$

$$M_i^c = \alpha_{M_i^c} \left[\begin{array}{c} \sum_{fc \in W} \beta_{MM_i^{c,fc}} MM_i^{c,fc} \frac{\sigma_{M_i} - 1}{\sigma_{M_i}} \\ + \beta_{MMJ_i^c} MMJ_i^c \frac{\sigma_{M_i} - 1}{\sigma_{M_i}} \end{array} \right]^{\frac{\sigma_{M_i}}{\sigma_{M_i} - 1}}, \quad (61)$$

$$MM_i^{c,fc} = \left[\frac{\alpha_{M_i^c} \beta_{MM_i^{c,fc}} P_{M_i^c}}{(1 + \tau_{MM_i^{c,fc}}) P_{MM_i^{c,fc}}} \right]^{\sigma_{M_i}} \frac{M_i^c}{\alpha_{M_i^c}}, \quad (62)$$

$$MMJ_i^c = \left[\frac{\alpha_{M_i^c} \beta_{MMJ_i^c} P_{M_i^c}}{(1 + \tau_{MMJ_i^c}) P_{MMJ_i^c}} \right]^{\sigma_{M_i}} \frac{M_i^c}{\alpha_{M_i^c}}, \quad (63)$$

$$Q_i^c = \alpha_{DM_i^c} \left[\beta_{DD_i^c} D_i^c \frac{\sigma_{Q_i} - 1}{\sigma_{Q_i}} + \beta_{M_i^c} M_i^c \frac{\sigma_{Q_i} - 1}{\sigma_{Q_i}} \right]^{\frac{\sigma_{Q_i}}{\sigma_{Q_i} - 1}}, \quad (64)$$

$$D_i^c = \left[\frac{\alpha_{DM_i^c} \beta_{DD_i^c} P_{Q_i^c}}{P_{D_i^c}} \right]^{\sigma_{Q_i}} \frac{Q_i^c}{\alpha_{DM_i^c}}, \quad (65)$$

$$M_i^c = \left[\frac{\alpha_{DM_i^c} \beta_{M_i^c} P_{Q_i^c}}{P_{M_i^c}} \right]^{\sigma_{Q_i}} \frac{Q_i^c}{\alpha_{DM_i^c}}, \quad (66)$$

$$P_{EE_i^{c,fc}} = \varepsilon^c P_{WE_i^c}, \quad (67)$$

$$P_{EEJ_i^c} = \varepsilon^c P_{WE_i^c}, \quad (68)$$

$$P_{MM_i^{c,fc}} = \varepsilon^c P_{WM_i^c}, \quad (69)$$

$$P_{MMJ_i^c} = \varepsilon^c P_{WM_i^c}. \quad (70)$$

10. Market equilibrium conditions of foreign countries:

$$Q_i^c = \sum_{j \in J} X_{ij}^c + XH_i^c + XG_i^c + XI_i^c, \quad (71)$$

$$\sum_{j \in J} LAB_j^c = F_{LAB^c}, \quad (72)$$

$$\sum_{j \in J} K_j^c = F_{K^c}, \quad (73)$$

$$\sum_{j \in J} LAN_j^c = F_{LAN^c}, \quad (74)$$

$$\sum_{j \in J} ENE_j^c = F_{ENE^c}. \quad (75)$$

11. Equilibrium conditions between MRCGE and MRCGE-GTAP:

$$\sum_{r \in R} E_i^r = \sum_{c \in C} MMJ_i^c, \quad (76)$$

$$\sum_{r \in R} M_i^r = \sum_{c \in C} EEJ_i^c, \quad (77)$$

$$MM_i^{c,fc} = EE_i^{fc,c}, \quad (78)$$

$$P_{WE_i^c} = P_{WM_i^c}, \quad (79)$$

$$P_{WM_i^c} = P_{WE_i^{fc}}, \quad (80)$$

$$P_{WM_i^c} = P_{WE_i^{fc}}. \quad (81)$$

Table 2A. Categorizations of industry and elasticity of substitution

We consider the consistency between 47 interregional I/O and GTAP database "GTAP7" because we sought to develop the combination model of this MRCGE and GTAP-E. The industrial sector categorization of this MRCGE-GTAP is shown below.

Category of industry of MRCGE-GTAP		Elasticity of substitution		
		σ_{VA_j}	σ_{Q_i}	σ_{M_i}
(1) Agriculture, forestry and fishery (<i>AGR</i>)	Agriculture, forestry, fisheries	0.2	2.4	4.8
(2) Mining (<i>MIN</i>)	Mining	0.2	5.7	12.1
(3) Petroleum and coal products (<i>PET</i>)	Petroleum products, coal products	1.3	2.1	4.2
(4) Chemical products (<i>CHE</i>)	Chemical products, plastic products, rubber products	1.3	3.3	6.6
(5) Other ceramic, stone and clay products (<i>CER</i>)	Other ceramic, stone and clay products	1.3	2.9	5.8
(6) Steel products (<i>STL</i>)	Steel products	1.3	3.0	5.9
(7) Other iron or steel products (<i>OSTL</i>)	Other iron or steel products	1.3	4.2	8.4
(8) Machines (<i>MCH</i>)	Electronic components, machinery for office and service industry, household electronic and electric appliances, other general machines, other electrical equipment, general industrial machinery, special industrial machinery	1.3	4.2	8.4
(9) Automobiles (<i>CAR</i>)	Cars	1.3	2.8	5.6
(10) Other manufacturing industry (<i>MAN</i>)	Foods and tobacco, wearing apparel and other textile products, timber and wooden products, pulp, paper and paper products, publishing and printing, leather, fur skins and miscellaneous leather products, metal products, other metal products, furniture and fixtures	1.2	3.2	6.5
(11) Civil engineering and construction (<i>CON</i>)	Civil engineering and construction, other civil engineering and construction	1.4	1.9	3.8
(12) Electric power (<i>ELE</i>)	Electric power	1.3	2.8	5.6
(13) Gas and heat supply (<i>GAS</i>)	Gas and heat supply	1.3	2.8	5.6
(14) Transport (<i>TRA</i>)	Transport	1.7	1.9	3.8
(15) Services (<i>SER</i>)	Finance and insurance, communication and broadcasting, public services, medical service and social security, other public services, education and research, water supply and waste management services, business services, real estate, personal services, commerce, others	1.3	1.9	3.8