

“Profit modelling of insurance companies on the basis of network planning”

AUTHORS

Viktor Oliynyk  <http://orcid.org/0000-0001-6251-3846>

ARTICLE INFO

Viktor Oliynyk (2015). Profit modelling of insurance companies on the basis of network planning. *Insurance Markets and Companies*, 6(1), 44-52

RELEASED ON

Thursday, 30 July 2015

JOURNAL

"Insurance Markets and Companies"

FOUNDER

LLC “Consulting Publishing Company “Business Perspectives”



NUMBER OF REFERENCES

0



NUMBER OF FIGURES

0



NUMBER OF TABLES

0

© The author(s) 2025. This publication is an open access article.

Viktor Oliynyk (Ukraine)

Profit modelling of insurance companies on the basis of network planning

Abstract

The author investigates the essence of the network planning method. And develops the scientific and methodical approach to profit modeling of insurance companies based on the instruments of network planning, which makes it possible to assess the profits of insurance companies both in terms of minimization of time required to carry out the work and minimization of its implementation costs.

Keywords: insurance company, profits, modeling, network planning.

Introduction

Problem statement. In modern conditions of functioning of the insurance market insurers have two important objectives, namely: on the one hand, the need to increasingly focus on customer's wishes and, on the other hand, to constantly improve the company's performance. To fulfil these requirements insurance companies have to carry out continuous monitoring of their operational and investment activities. In this context it should be noted that the effectiveness of the insurer depends on financial planning, especially the forecasting of financial results. The experience of developed countries shows that profit forecasting as an absolute final indicator of the insurance company's performance, makes it possible to avoid major failures and associated losses. Therefore, it is very important to determine and use the predictive model of profit at the insurance company.

Earlier unresolved parts of the problem. In spite of the obvious character of the concept "insurance company's profits" there is no single clearly defined and universally accepted method of evaluation of the company's effectiveness. Despite the diversity and depth of the conducted research there remains the unsolved problem of developing a scientific and methodical approach to profit modeling of insurance companies.

The goal of the article is to develop scientific and methodical approach to the modeling of insurance companies' profits on the basis of network planning.

1. Analysis of recent publications

The assessment and planning of insurance companies' profits have been intensively studied by scientists. Researchers and practitioners studying this problem include: Cummins [2], Liebenberg [8], Elango [4], Eling, V.D. Bazylevych [1] O.V. Kozmenko [6, 7] and others.

In particular, based on the data analysis of risk insurance companies for ten years, Cummins and Xie [2] have concluded that most insurers with their size below average have increasing returns to scale, and most companies with the size above average have decreasing returns to scale. In paper Liebenberg and Sommer [8] identified the dependence of profitability of insurance business on the level of diversification activities.

2. Presentation of the main material

Under conditions of increasing riskiness and uncertainty, managers of insurance companies have a growing responsibility to ensure the efficiency of operational and investment activities. The specific nature of insurance companies' activities cause the necessity to determine a system of indicators for the monitoring of financial results. The system of indicators should characterize the peculiarities in the functioning of insurance companies; analyze the impact of various factors on the processes of management.

To ensure the effective planning of insurance companies' profits we propose to use network planning, which involves optimization of the fulfilled work package consisting of separate, interconnected links, the implementation of which should be subject to a clearly defined logical sequence.

Let us proceed to the actual algorithm for this method. At the first stage we conduct identification of works describing the system of planning of insurance companies' profits, their formalization through the use of symbols and grouping of works to provide quality characteristics.

The second stage involves the assessment of a system of profit planning for further formation of input data array in the context of determining the time of execution and costs for implementation of works. The testing results of this scientific and methodical approach at the 1st and 2nd stages are graphically depicted in Fig. 1 and in the form of structural Table 1.

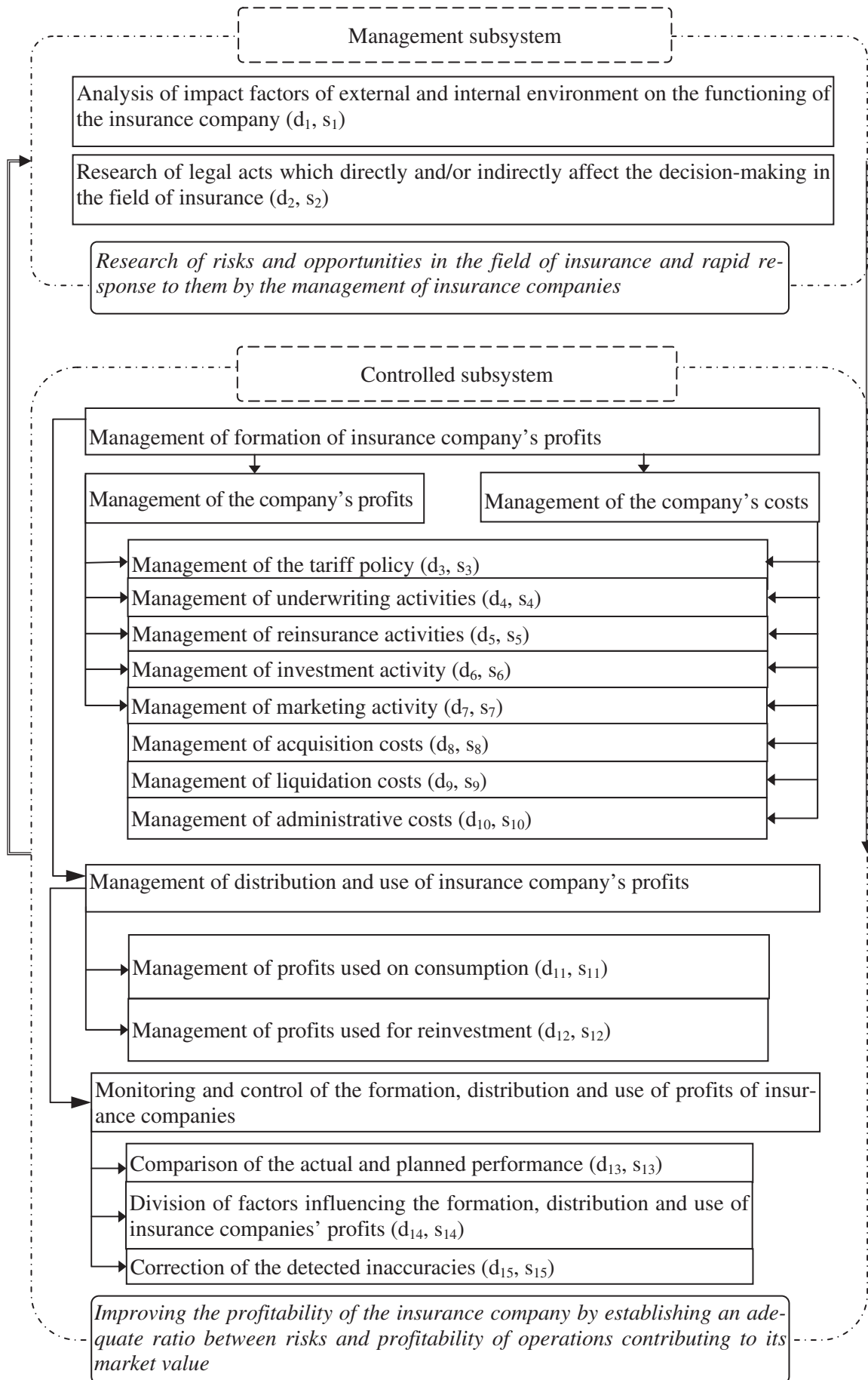

Fig. 1. Graphical representation of the system's transition graph

Table 1. Structural table of the transition graph for the system of planning of insurance companies' profits

Groups of work packages	Symbol of work	Immediately preceding works	Time of execution (during a year)	Costs of implementation
Research of risks and opportunities in the field of insurance and rapid response to them by the management of insurance companies	a1	-	d ₁	s ₁
	a2	-	d ₂	s ₂
Management of formation of insurance companies' profits	a3	a1, a2	d ₃	s ₃
	a4	a1, a2	d ₄	s ₄
	a5	a1, a2	d ₅	s ₅
	a6	a1, a2	d ₆	s ₆
	a7	a1, a2	d ₇	s ₇
	a8	a3, a4, a5, a6, a7	d ₈	s ₈
	a9	a3, a4, a5, a6, a7	d ₉	s ₉
	a10	a3, a4, a5, a6, a7	d ₁₀	s ₁₀
Management of the distribution and use of insurance companies' profits	a11	a8, a9, a10	d ₁₁	s ₁₁
	a12	a8, a9, a10	d ₁₂	s ₁₂
Monitoring and control of the formation, distribution and use of profits of insurance companies	a13	a11, a12	d ₁₃	s ₁₃
	a14	a11, a12	d ₁₄	s ₁₄
	a15	a11, a12	d ₁₅	s ₁₅

Notes: a1 – analysis of impact factors of external and internal environment on the functioning of the insurance company; a2 – research of legal acts which directly and/or indirectly affect the decision-making in the field of insurance; a3 – management of the tariff policy; a4 – management of underwriting activities; a5 – management of reinsurance activities; a6 – management of investment activity; a7 – management of marketing activity; a8 – management of acquisition costs; a9 – management of liquidation costs; a10 – management of administrative costs; a11 – management of profits used on consumption; a12 – management of profits used for reinvestment; a13 – comparison of the actual and planned performance; a14 – division of factors influencing the formation, distribution and use of insurance companies' profits; a15 – correction of the detected inaccuracies.

The next stage (the third) is the ranking of work packages of the transition graph for the system of planning. The practical implementation of this phase aims to introduce:

- ◆ works of rank 1, which do not envisage the implementation of the preceding link. These are the works a1, a2, which are given a new symbol b1, b2;
- ◆ works of rank 2, which are preceded only by works of rank 1 (a1, a2). The second rank is designated to works a3, a4, a5, a6, a7. In the new system of symbols these links receive the following designation b3, b4, b5, b6, b7;
- ◆ works of rank 3, namely those elements that can be implemented only after the completion of the previous two ranks. It should be noted that this group has the greatest specific weight (10 components), and includes the following links: a8, a9, a10, (respectively b8 – b10);
- ◆ works of the 4th, 5th and 6th ranks, the determination of which is made similar to the earlier described method.

We propose to present the results of the testing of this stage (the ranking of works) in Table 2.

Table 2. Structural table of the ranking of work packages of the transition graph for the system of planning of insurance companies' profits

Symbol of work	Immediately preceding works	Rank	Ranking of works	Immediately preceding works
a1	-	1	b1	-
a2	-	1	b2	-
a3	a1, a2	2	b3	b1, b2
a4	a1, a2	2	b4	b1, b2
a5	a1, a2	2	b5	b1, b2
a6	a1, a2	2	b6	b1, b2
a7	a1, a2	2	b7	b1, b2
a8	a3, a4, a5, a6, a7	3	b8	b3, b4, b5, b6, b7
a9	a3, a4, a5, a6, a7	3	b9	b3, b4, b5, b6, b7
a10	a3, a4, a5, a6, a7	3	b10	b3, b4, b5, b6, b7
a11	a8, a9, a10	4	b11	b8, b9, b10

Table 2 (cont.). Structural table of the ranking of work packages of the transition graph for the system of planning of insurance companies' profits

Symbol of work	Immediately preceding works	Rank	Ranking of works	Immediately preceding works
a12	a8, a9, a10	4	b12	b8, b9, b10
a13	a11, a12	5	b13	b11, b12
a14	a11, a12	5	b14	b11, b12
a15	a11, a12	5	b15	b11, b12

The fourth stage is the interpretation of the insurance company's profits planning system by introducing transition graph for the network planning of management, namely, by conducting the characterization of events and works. It should be noted that the works are marked by small letters while the events

are characterized by capital letters. In addition, on the network graph of the work package of Table 2 events are designated with a circle, while the works are designated with aimed arrows, the beginning and end of which mean respective events (Fig. 2, where B0 stands for initial event, and B16 – for final event).

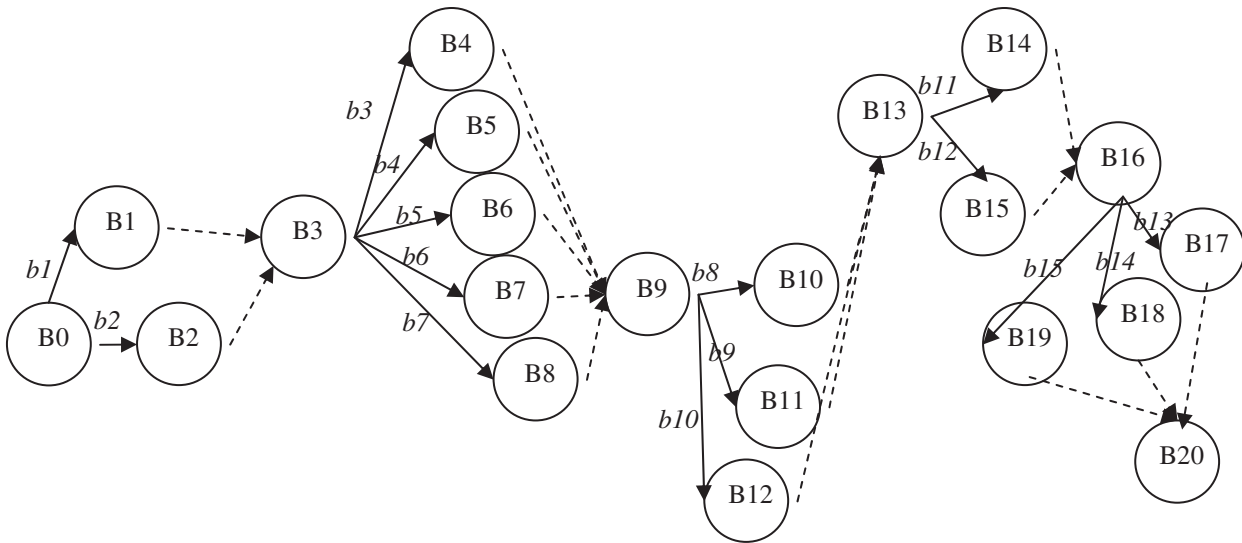

Fig. 2. Network graph of the work package of Table 2 for the planning of insurance companies' profits

The next (fifth) algorithm stage is to carry out a quantitative evaluation of elements of the network work package graph for the insurance companies' planning profits. The purpose of this stage is to determine the duration of works over the arrows and the time of beginning (ending) according to the numbers given above the events. Also, within this stage a prominent place belongs to the determination of the critical path of the network graph, such as a par-

ticular sequence of works (Table 3, Figure 3). After analyzing the data of Fig. 3 we can say that the planning of insurance companies' profits is conducted inefficiently as indicated by the data of the critical path at 468 hours, which is significantly higher than the specified number of 360 hours. Because of this, it is necessary to adjust the current status of profit planning conducted at the next stage of this approach.

Table 3. Structural table of the work package of transition graph for the insurance companies' profits planning system

Groups of work packages	Symbol of work	Time of execution (during a year)	Costs of implementation
Research of risks and opportunities in the field of insurance and rapid response to them by the management of insurance companies	a1	24 hours	507.60
	a2	68 hours	2480.56
Insurance companies formation management profits	a3	80 hours	2800.6
	a4	76 hours	3360.92
	a5	84 hours	1240.28
	a6	104 hours	3440.68
	a7	60 hours	1194.6
	a8	48 hours	1195.68
	a9	96 hours	1391.36
	a10	96 hours	1560.32
Management of the distribution and use of insurance companies' profits	a11	96 hours	1560.32
	a12	104 hours	1773.68

Table 3 (cont.). Structural table of the work package of transition graph for the insurance companies profits planning system

Groups of work packages	Symbol of work	Time of execution (during a year)	Costs of implementation
Monitoring and control of the formation, distribution and insurance companies profits use	a13	76 hours	4361.92
	a14	96 hours	1560.32
	a15	8 hours	213.36

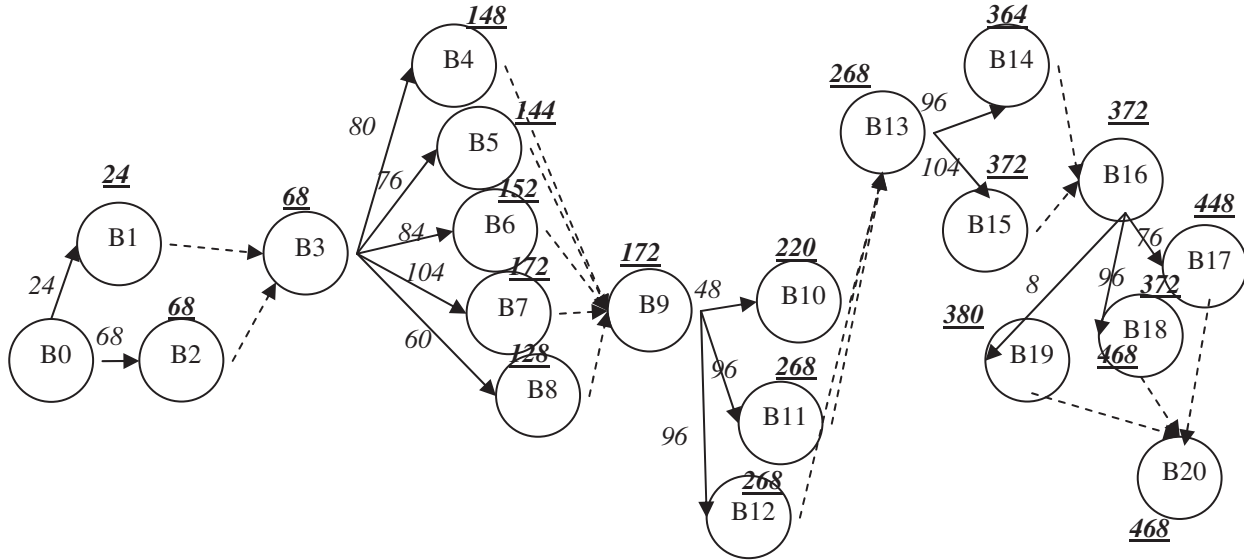

Fig. 3. Work package network graph critical path determination for the planning of insurance companies' profits

It should be said that the implementation of the sixth stage makes it possible to ensure effective planning of companies' profits depending on the tactical plans and strategic management through the use of the CPM method (Critical Path Method).

It should be noted that the testing of this approach is intended to perform the following algorithm. The project of implementation of profit planning will be described with a network graph. For each specific

work we know its duration t_i and its minimal possible runtime d_i . The time of project's implementation corresponds to the level t_0 , while the calculated value of the critical path (maximal duration of implementing the whole work package) $t_{cr} > t_0$. In addition, the duration of the work implementation depends linearly on the amount of additional investments and is expressed by the ratio: $t'_i = t_i - k_i x_i$. Technological coefficients k_i and input data are presented in Table 4.

Table 4. Information base for conducting the insurance companies' profits planning on the basis of network planning

Work	Parameters of the model		
	Duration t_i	Minimal possible runtime d_i	Technological coefficients k_i
b1	24 hours	16 hours	0.667
b2	68 hours	52 hours	0.765
b3	80 hours	68 hours	0.850
b4	76 hours	58 hours	0.763
b5	84 hours	72 hours	0.857
b6	104 hours	96 hours	0.923
b7	60 hours	48 hours	0.800
b8	48 hours	36 hours	0.750
b9	96 hours	84 hours	0.875
b10	96 hours	82 hours	0.854
b11	96 hours	86 hours	0.896
b12	104 hours	86 hours	0.827
b13	76 hours	72 hours	0.947
b14	96 hours	78 hours	0.813
b15	8 hours	6 hours	0.750
Period of the project's realization	394		
Costs of the project's realization	30000 hours		

Depending on the tactical plans and strategic management we propose to describe the effective planning of insurance companies' profits on the basis of network planning with the help of the following components:

- by minimizing the costs for implementing the work package as part of the planning of insurance companies' profits: the time of implementation of the whole work package shall not be less than t_0 ; the total amount of additionally invested funds should be at a minimal level; the duration of implementation of each work t_i should not be lower than d_i .
- by reducing the time of implementation of the work package related to the planning of insurance companies' profits: the time of implementation of the whole work package should be minimal; the number of the used additional instruments should not exceed the duration of each work and should not be lower than d_i .

We consider it necessary to emphasize that mathematical formalization of the proposed approach involves the determination of objective function, which makes it possible to quantitatively describe the chosen strategy to ensure efficiency. That is, if the management of the analyzed insurance company wishes to minimize the total amount of additionally

$$\begin{aligned}
 t^o_1 - t^h_1 &\geq 24 - 0.67x_1; t^o_2 - t^h_2 \geq 68 - 0.76x_2; t^o_3 - t^h_3 \geq 80 - 0.85x_3; \\
 t^o_4 - t^h_4 &\geq 76 - 0.76x_4; t^o_5 - t^h_5 \geq 84 - 0.86x_5; t^o_6 - t^h_6 \geq 104 - 0.92x_6; \\
 t^o_7 - t^h_7 &\geq 60 - 0.80x_7; t^o_8 - t^h_8 \geq 48 - 0.75x_8; t^o_9 - t^h_9 \geq 96 - 0.88x_9; \\
 t^o_{10} - t^h_{10} &\geq 96 - 0.85x_{10}; t^o_{11} - t^h_{11} \geq 96 - 0.90x_{11}; t^o_{12} - t^h_{12} \geq 104 - 0.83x_{12}; \\
 t^o_{13} - t^h_{13} &\geq 76 - 0.95x_{13}; t^o_{14} - t^h_{14} \geq 96 - 0.81x_{14}; t^o_{15} - t^h_{15} \geq 8 - 0.75x_{15};
 \end{aligned} \tag{4}$$

- 4) the next important aspect is the dependence of the start of implementation of each work on the time of completion of the previous work. The starting time should not be less than the time of completion as shown by in equation 5:

$$\begin{aligned}
 t^h_1 &= 0; t^h_2 = 0; t^h_3 \geq t^o_1; & t^h_9 &\geq t^o_3; t^h_9 \geq t^o_4; t^h_9 \geq t^o_5; \\
 t^h_4 &\geq t^o_1; t^h_3 \geq t^o_2; & t^h_9 &\geq t^o_6; t^h_9 \geq t^o_7; t^h_{10} \geq t^o_3; \\
 t^h_4 &\geq t^o_2; t^h_5 \geq t^o_1; t^h_5 \geq t^o_2; & t^h_{10} &\geq t^o_4; t^h_{10} \geq t^o_5; t^h_{10} \geq t^o_6; \\
 t^h_6 &\geq t^o_1; t^h_6 \geq t^o_2; t^h_7 \geq t^o_1; & t^h_{10} &\geq t^o_7; t^h_{11} \geq t^o_8; t^h_{11} \geq t^o_9; \\
 t^h_8 &\geq t^o_2; t^h_8 \geq t^o_3; t^h_8 \geq t^o_5; & t^h_{11} &\geq t^o_{10}; t^h_{12} \geq t^o_8; t^h_{12} \geq t^o_9; \\
 t^h_7 &\geq t^o_2; t^h_8 \geq t^o_3; t^h_8 \geq t^o_4; & t^h_{12} &\geq t^o_{10}; t^h_{13} \geq t^o_{11}; t^h_{13} \geq t^o_{12}; \\
 t^h_8 &\geq t^o_5; t^h_8 \geq t^o_6; t^h_8 \geq t^o_7; & t^h_{14} &\geq t^o_{11}; t^h_{14} \geq t^o_{12}; t^h_{15} \geq t^o_{11}; \\
 & & & t^h_{15} \geq t^o_{12};
 \end{aligned} \tag{5}$$

- 5) In the construction of economic and mathematical models for the efficient planning of profits the condition of inseparable unknowns should be met (in equation 6):

$$t^h_i \geq 0, t^o_i \geq 0, x_i \geq 0. \tag{6}$$

Having applied the "Solver" instrument of the MS Excel program we propose to carry out the sixth stage

invested funds, the objective function can be presented as follows:

$$\min F = \sum_{i=1}^{15} x_i. \tag{1}$$

In the context of this research it is necessary to consider a set of restrictions that not only hamper effective implementation, but also affect the efficiency of the insurance company's functioning. That is why during the construction of economic and mathematical models for effective planning of insurance companies' profits the following aspects should be considered:

- 1) the duration of the project's implementation should not exceed $t_0 = 394$:

$$t^o_{15} \leq 394 \tag{2}$$

- 2) the duration of implementation of each work should not be less than the minimal possible runtime (in equation 3):

$$\begin{aligned}
 t^o_1 - t^h_1 &\geq 16; t^o_2 - t^h_2 \geq 52; t^o_3 - t^h_3 \geq 68; \\
 t^o_4 - t^h_4 &\geq 58; t^o_5 - t^h_5 \geq 72; t^o_6 - t^h_6 \geq 96; \\
 t^o_7 - t^h_7 &\geq 48; t^o_8 - t^h_8 \geq 36; t^o_9 - t^h_9 \geq 84; \\
 t^o_{10} - t^h_{10} &\geq 82; t^o_{11} - t^h_{11} \geq 86; t^o_{12} - t^h_{12} \geq 86; \\
 t^o_{13} - t^h_{13} &\geq 72; t^o_{14} - t^h_{14} \geq 78; t^o_{15} - t^h_{15} \geq 6;
 \end{aligned} \tag{3}$$

- 3) it is necessary to consider the dependence of work duration on invested funds:

of effective planning of insurance companies' profits on the basis of network planning.

It should be noted that the application of the CPM method to optimize the network graph for effective planning of insurance companies' profits makes it possible to obtain the results that are presented in Table 5.

Table 5. Network graph optimization results for effective planning of insurance companies' profits

Amount of additionally invested funds		Starting time for implementation of works		Time of completion of work implementation		Duration of work implementation (optimal)	Duration of implementation of works (initial)	Reduction in the duration of works	Specific weight of reduction of time needed for work implementation
1	2	3	4	5	6	7	8	9	10
29.99	t ¹	0	t ¹	20	20	24	4	16.67	
67.97	t ²	0	t ²	52	52	68	16	23.53	
88.24	t ³	52	t ³	127	75	80	5	6.25	
78.64	t ⁴	52	t ⁴	112	60	76	16	21.05	
93.35	t ⁵	52	t ⁵	132	80	84	4	4.76	
104.01	t ⁶	52	t ⁶	148	96	104	8	7.69	
62.50	t ⁷	52	t ⁷	102	50	60	10	16.67	
53.33	t ⁸	148	t ⁸	188	40	48	8	16.67	
96.00	t ⁹	148	t ⁹	232	84	96	12	12.50	
96.02	t ¹⁰	148	t ¹⁰	230	82	96	14	14.58	
95.98	t ¹¹	232	t ¹¹	318	86	96	10	10.42	
103.99	t ¹²	232	t ¹²	318	86	104	18	17.31	
78.14	t ¹³	318	t ¹³	392	74	76	2	2.63	
95.94	t ¹⁴	318	t ¹⁴	396	78	96	18	18.75	
8.00	t ¹⁵	318	t ¹⁵	324	6	8	2	25.00	

The final stage of the algorithm for network planning of insurance companies' profits is a qualitative interpretation of network graph optimization results (stage 7). It is carried out both in the context of minimization of time needed for implementation of work package and minimization of costs.

On the basis of the data of Table 5 we construct the optimal network graph for this process (Fig. 4). The main purpose of the study is to ensure the efficient planning of insurance companies' profits by minimizing the costs of implementing work packages.

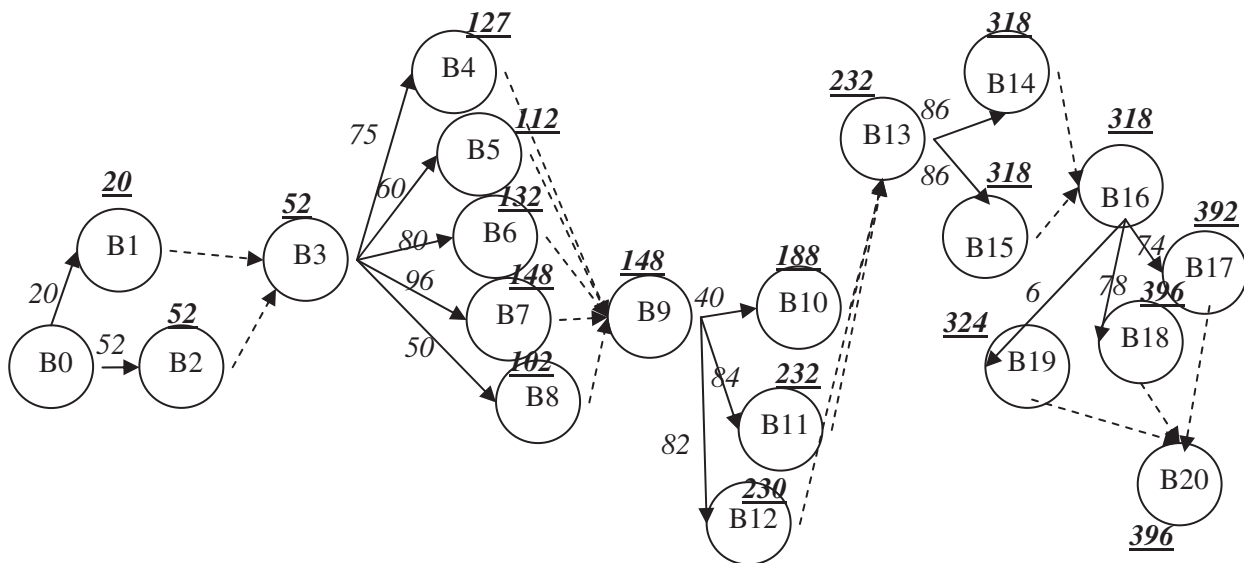

Fig. 4. Optimal network graph of efficient planning of insurance companies' profits through minimization of invested funds

On the basis of the analysis presented in Fig. 4 we can draw the following conclusions: first of all, we propose to determine 396 hours as the total time to carry out the whole work project of insurance companies' profits planning. It should be noted that this figure is 72 hours (or 15.38%) less than the critical path; on the basis of the data presented in Table 5 we propose to reduce the time of implementation of work package by reducing the time of work implementation in graph 9; an important aspect is the reduction of time due to additionally borrowed funds,

the minimal amount of which is 1152.10 hryvnias.

We can add that the biggest amounts should be used to execute the types of works such as "Management of investment activity" and "Management of profits used for reinvestment".

Thus, having studied all the necessary aspects of the proposed model we can introduce a generalized scheme of network planning for insurance companies' profits (Fig. 5).

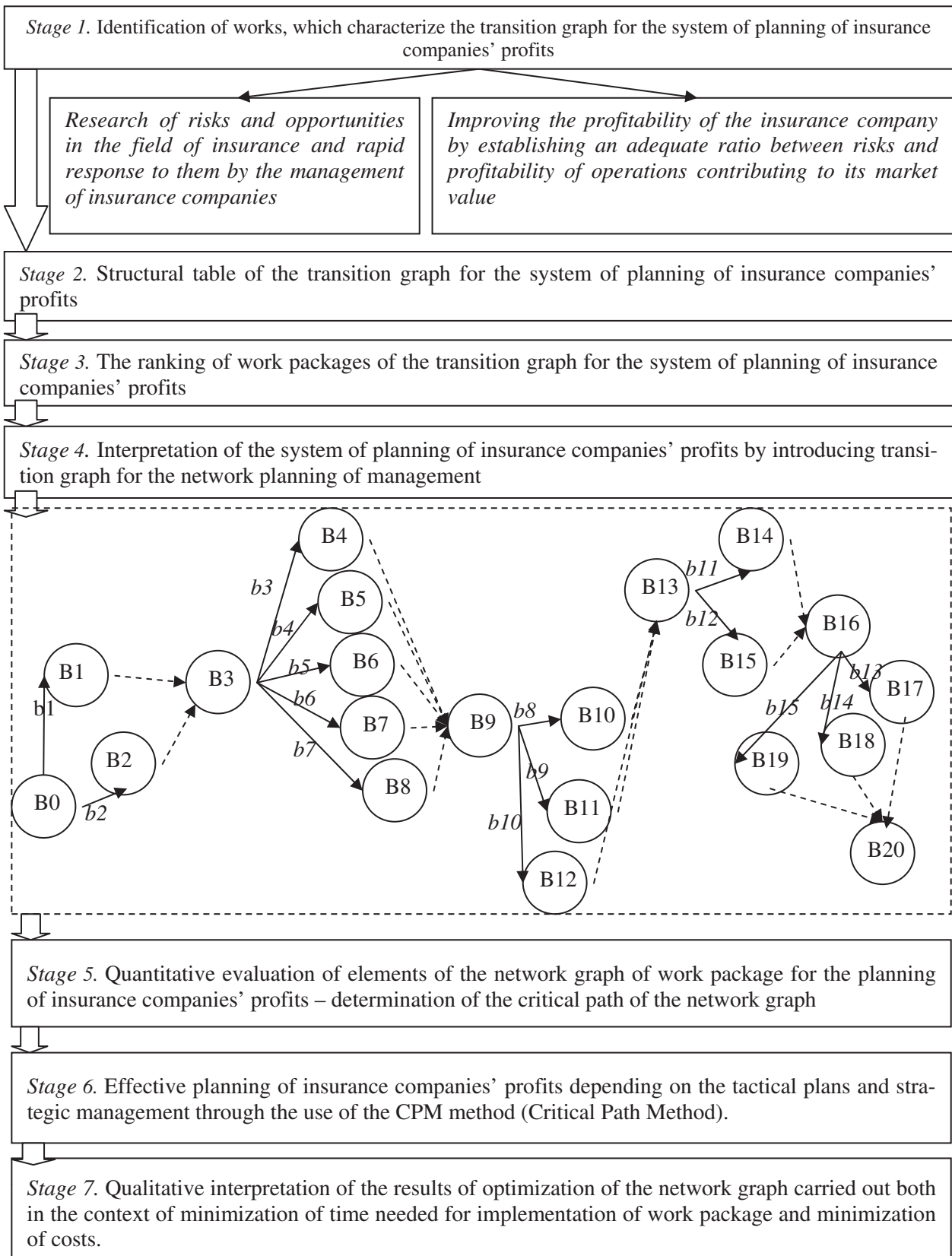

Fig. 5. Generalized scheme of network planning of insurance companies' profits

Conclusion

The proposed model is very effective for the modeling of insurance companies' profits. The use of the network planning instruments is a method involving the optimization of the fulfilled work package consisting of separate, interconnected links, the implementation of which

should be subject to a clearly defined logical sequence. By using this scientific and methodical approach for modeling insurance companies' profits we can conduct the planning of insurance companies' profits both in the context of minimization of time needed for implementation of work package and minimization of costs.

References

1. Bazylevych, V.O. (2008). Strakhova sprava: monograph by V.O. Bazylevych, K.S. Bazylevych, 6th ed., Kyiv: Znannia, 351 p.
2. Cummins, D.J., & Xie, X. (2008). Efficiency, productivity, and scale economies in the US property-liability insurance industry. Working Paper, Temple University
3. Druzhinin, N.K. (1971). *Matematicheskaya statistika v ekonomike: Vvedeniye v matematiko-statisticheskuiu metodologiyu*. Moscow: Statistika, 264.
4. Elango, B., Ma, Y.L., & Pope, N. (2008). An investigation into the diversification-performance relationship in the US property-liability insurance industry, *Journal of Risk and Insurance*, 75 (3), pp. 567-591
5. Hryshchenko, N.B. (2009). *Osnovy strakhovoi deiatelnosti: uchebnoe posobiie*, Barnaul, 274 p.
6. Kozmenko, O.V. (2012). Metodichni pidkhody do otsinky rivnia konkurentzii rynku perestrakhuvannia Ukrainy. In monograph by O.V. Kozmenko, O.V. Kuzmenko. Novi vektory rozvytku strakhovogo rynku Ukrainy. Ed. by Kozmenko, O.V., Kozmenko, S.M., Vasyljeva, T.A. et al. Sumy: Universitetska knyga, pp. 154-169.
7. Kozmenko, O.V. (2011). Modeljuvannia stabilizatsiinykh protsesiv na rynku perestrakhuvannia Ukrainy. In monograph Strakhovyi i perestrakhovyi rynky v epokhu globalizatsii. Ed. by Kozmenko, O.V., Kozmenko, S.M., Vasyljeva, T.A. et al. Sumy: Universitetska knyga, pp. 111-114.
8. Liebenberg, A.P. & Sommer, D.W. (2008). Effects of corporate diversification: Evidence from the property-liability insurance industry, *Journal of Risk and Insurance*, 75 (4), 893-919